

Translation of Original Installation/Use/Maintenance Instructions

LTG Air-Water Systems

LTG Decentral

Decentralized ventilation units

FVS-600 *Eco₂School*

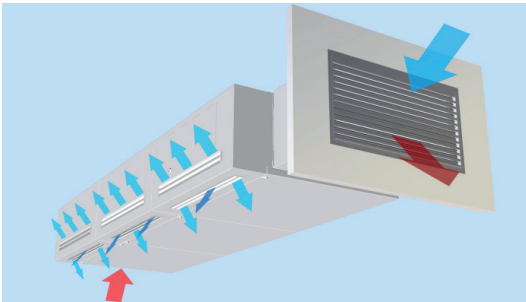

Installation below/in the ceiling and on the wall

Table of contents, Notes

| | |
|-----------------------------------------------------------------------------------|--|
| LTG Comfort Air Technology | |
|  | |
| Air Diffusers | |
| Air Distribution | |

| Table of contents | Page |
|-------------------------------------------------------------|------|
| 1. EC Declaration of conformity | 3 |
| 2. Safety instructions | 4 |
| 2.1 Explanation of symbols and hints | 4 |
| 2.2 Operating safety instructions | 4 |
| 3. Transport, storage, delivery | 6 |
| 3.1 Transport instructions | 6 |
| 3.2 Storage | 6 |
| 3.3 Delivery | 6 |
| 4. Function | 6 |
| 4.1 Controller operational mode | 7 |
| 4.2 Intended use | 9 |
| 4.3 Notes for users | 10 |
| 5. Technical data | 10 |
| 5.1 Ventilation unit | 10 |
| 5.2 Re-heater | 11 |
| 5.3 Re-cooler | 13 |
| 6. Installation | 14 |
| 6.1 Installation notes | 14 |
| 6.2 Suspension of the unit | 15 |
| 6.3 Connection to the facade | 32 |
| 6.4 Electrical connections | 36 |
| 6.5 Check after installation | 42 |
| 7. Commissioning | 43 |
| 7.1 Function test | 43 |
| 7.2 Alarm, malfunctions | 43 |
| 8. Operation, maintenance, repair | 45 |
| 8.1 Opening the unit | 45 |
| 8.2 Filter change | 46 |
| 8.3 Inspect heat recovery unit, clean | 46 |
| 8.4 Cleaning the surfaces and fans | 49 |
| 8.5 Intervals for hygiene inspection and cleaning | 49 |
| 8.6 Repair, replacing a fan | 49 |
| 8.7 Repair, replacement of the spring return drive | 49 |
| 8.8 Repair, exchange heat recuperator bypass flap | 50 |
| 8.9 Replace backup battery (button cell) for Climatix timer | 50 |
| 9. Spare Parts, accessories | 51 |
| 10. Decommissioning, disposal | 51 |

Notes

Dimensions stated in this brochure are in mm.

Dimensions stated in this brochure are subject to General Tolerances according to DIN ISO 2768-vL.

For the outlet grille special tolerances stated in the drawing apply.

Straightness and twist tolerances for extruded aluminium profiles according to DIN EN 12020-2.

The surface finish was designed for use in buildings - indoor climate according to DIN 1946 Part 2. Other requirements on request

EC Declaration of conformity

1. EC Declaration of conformity



EC declaration of conformity

As defined by the EC Council Directive on Machinery 2006/42/EC, Annex II, Nr. 1A

We herewith declare that the machine described in the following conforms to all relevant provisions of the EC Machinery Directive 2006/42/EC.

Manufacturer: **LTG Aktiengesellschaft
Grenzstr. 7, 70435 Stuttgart,
Germany**

Designation of machinery: **Decentralised Ventilation Unit**

Machinery type: **FVS-600 ECO₂School**

Relevant EC Council Directives: **Low Voltage Directive 2014/35/EC,
Energy-related products 2009/125/EC,
Ecodesign Requirements for Fans EU No 327/2011**

Applied harmonized standards, in particular: **DIN EN ISO 12100, DIN EN ISO 13854,
DIN EN ISO 13857, DIN EN 60335-2-40**

Other standards: **DIN EN 60204-1, DIN EN 13463-1, DIN EN 60730-1,
DIN EN 60730-2-14, DIN EN 50121-3-2, DIN EN 61000-6-2,
DIN EN 61000-6-3, DIN EN 60034-1, DIN EN ISO 5801,
DIN EN 61326-1, DIN EN 61326-2-3, DIN EN 61000-6-1**

Stuttgart, 28.07.2021

Signature of manufacturer

Position of signatory:

Wagner
ppa. Dehlwes

Innovative Solutions for Humans and Products.

LTG Aktiengesellschaft
Grenzstraße 7, 70435 Stuttgart
Germany

Tel. +49 711 8201-0
Fax: +49 711 8201-720
info@LTG.de
www.LTG.net

Executive board:
Dipl.-Ing. Wolf Hartmann (chairman)
Dipl.-Ing. Ralf Wagner

Chairman of the supervisory board:
Dr. Franz Wimpffen

USt.-IdNr. / VAT Reg No.:
DE 812753932

Trade register:
district court Stuttgart,
No. HRB 20451
Place of performance / court
of jurisdiction Stuttgart

Bank details:
Landesbank Baden-Württemberg, Stuttgart
IBAN: DE34 6005 0101 0002 5756 67
SWIFT-BIC: SOLADEF600

Commerzbank AG, Stuttgart
IBAN: DE44 6004 0071 0755 0031 00
SWIFT-BIC: COBADEFFXXX

Safety

2. Safety instructions

| | |
|-----------------------------------------------------------------------------------|-----------------------------------------------------------------------------------------------------------------------------------------------|
|  | <p>Assembly, dismantling and maintenance must be performed by trained personnel in order to achieve reliability, safety and best results.</p> |
|-----------------------------------------------------------------------------------|-----------------------------------------------------------------------------------------------------------------------------------------------|

2.1 Explanation of symbols and hints

Operating safety symbol

| | |
|-----------------------------------------------------------------------------------|------------------------------------------------------------------------------------------------------------------------------------------------------------------------------------------------------------------------------------------------------------------------------------------------------------------------------------------------------------------------------------------------------------------------------------------------------------------------------------------------------------------------|
|  | <p>This symbol is placed alongside every operating safety instruction in these operating instructions, wherever there is a danger to life and limb. Observe these instructions and in such cases proceed with extreme caution. Pass on all the operating safety instructions to other users. In addition to the instructions contained in these operating instructions, the generally applicable safety and accident prevention regulations must be observed; as shown here, for example: Warning of hazard point.</p> |
|-----------------------------------------------------------------------------------|------------------------------------------------------------------------------------------------------------------------------------------------------------------------------------------------------------------------------------------------------------------------------------------------------------------------------------------------------------------------------------------------------------------------------------------------------------------------------------------------------------------------|

Information symbol

| | |
|-------------------------------------------------------------------------------------|-----------------------------------------------------------------------------------------------------------------------------------------------------------------------------------------------------------------------------------------------------------------------------------------------------------------------------|
|  | <p>This information symbol is placed alongside those points in the manual which must be specifically observed in order to ensure that the guidelines, regulations, instructions and correct operating sequences are observed and to prevent damage to or destruction of the unit and/or other components in the system.</p> |
|-------------------------------------------------------------------------------------|-----------------------------------------------------------------------------------------------------------------------------------------------------------------------------------------------------------------------------------------------------------------------------------------------------------------------------|

| | |
|-------------------------------------------------------------------------------------|-----------------------------------------------------------------------------------------------------------------------------------------------------------------------------------------------------------------------------------------------------------------------------------|
|  | <p>These mandatory symbols are linked to the operating safety instructions and show which protective measures must be complied with at the appropriate workstations and therefore specifically mandate a certain action, as shown here as an example: Wear protective gloves.</p> |
|-------------------------------------------------------------------------------------|-----------------------------------------------------------------------------------------------------------------------------------------------------------------------------------------------------------------------------------------------------------------------------------|

| | |
|-------------------------------------------------------------------------------------|------------------------------------------------------------------------------------------------------------------------------------------------------------------|
|  | <p>These prohibition symbols are linked to the operating safety instructions banning a dangerous or risky action, as shown here as an example: Do not touch.</p> |
|-------------------------------------------------------------------------------------|------------------------------------------------------------------------------------------------------------------------------------------------------------------|

Safety

2.2 Operating safety instructions

Carefully read the safety instructions before using any LTG decentralized ventilation unit.

Always follow the safety instructions!

The units meet any pertinent safety standards.



The installation and maintenance of air conditioning units may be dangerous because of high pressures and electrical components being alive. Therefore, the installation, maintenance, and repair must be performed by qualified and trained staff only.

In particular, electrical connections are to be provided, removed, or modified by authorised persons only observing all relevant safety instructions.

Safety instructions in the technical documentation and on unit labels must be followed at all times.

Do not open the unit for cleaning, maintenance, or repair and do not remove covers and casings (air diffuser) unless all conducting lines have been completely disconnected. **Do not connect** or remove the plug-in connector when under tension.

Any work regarding the electrical equipment is to be performed by skilled and trained staff only. Connections to the main power supply and the safety earth terminal must be executed exactly as described in the wiring diagram.

Electrical operation of the unit in a partly disassembled condition or of individual components is not permitted since earth terminals might be interrupted.



During continuous operation the motor may reach temperatures of up to +65 °C. If necessary, allow the motor to cool off or wear gloves.



In the heating mode a temperature of up to 80 °C may be reached. Water-carrying parts may be hot, so do not touch with your bare hands to avoid burns.





Be careful when performing work on the heat exchangers. Blades and housing parts are sharp-edged. Wear gloves during work and handling.





The standard version of the heat exchangers is designed for an operating pressure of 10 bar (test pressure 16 bar). High water pressures may be hazardous. Higher operating pressures, therefore, require LTG's express permission. Wear safety glasses.





Be careful when working overhead and provide protection against parts falling from above.



Keep objects and dirt from entering the impeller. A damaged fan impeller or objects being ejected by the impeller may be hazardous.



The casing on site also serves as a protection and should be removed for maintenance and cleaning only.

Avoid any additional load to the unit or the suspensions since stability might be insufficient.

The unit must be checked by an expert immediately

- if it has been mechanically damaged
- if it is suffering from a water damage,
- if the fan shows signs of damage (imbalance, damage to the bearing or motor),
- if the suspension or the casing show clear signs of corrosion or ageing.

Do not put the unit back into operation before all necessary maintenance and repair has been performed!

Take the unit entirely off the main power supply until all repairs have been completed even if this might result in not being able to operate undamaged units.

It is in any case imperative to take a damaged unit completely off the main power supply!



Use the operating panel to disconnect the unit before starting any maintenance or repair work!

Disconnect the unit from the main power supply in all poles before opening the ventilation module!

Transport/storage/delivery

3. Transport, storage, delivery

The unit requires dry and dust-free conditions during transport, storage, installation, and operation.

Units are stacked on Euro or single trip pallets and secured with straps. Pallets may be moved using forklifts or cranes.

Do not remove the packaging unless immediately prior to installation on site to protect the unit from pollution and damages.



LTG Aktiengesellschaft will not take responsibility for any pollution of or damages to the unit.

3.1 Transport instructions

Handle units with care during transport. The outer shells **must not** be stressed in transport.

Do not throw, let drop to the ground or bump into other items or walls. Make sure that units are safely fastened during transport and avoid damage through other items.

At manual transport, the individual units should be moved with an industrial truck.

Forks of forklifts or pallet trucks must be supported over the entire width of the equipment. If this is not the case, wooden beams or board strips must be placed underneath. This support should preferably be provided close to the flanges.

The packaging is **not** weather-resistant.

3.2 Storage

Make sure that units are entirely protected against weathering, humidity, and other adverse conditions that might result in damages during storage.

The storage location must meet the following climatic requirements: Temperature between +5...+55 °C with a relative humidity of 90 % max. (non-condensing).

3.3 Delivery

Standard units are normally delivered as follows:

- 2 or 3 FVS-600 units on disposable pallet, pallet shrink-wrapped, dimensions approx. 210 x 110 x 120 cm, mass approx. 440 / 610 kg, outer service covers (3 per device) to protect against possible damage in transport / suspension loosely enclosed
- 4 Compact silencers on disposable pallet, dimensions approx. 190 x 102 x 190 cm, mass approx. 364 kg, devices shrink-wrapped
- for FVS-600/S (for visible installation) additionally one pallet per device with dimensions 230 x 70 cm, mass approx. 70 kg
- Assembly accessories (1 pallet per unit)
- Per device unit 2 x 6 m mounting rails

- on Euro or single trip pallets, secured with straps and/or with the pallet sealed in film
- fitting/regular accessories packaged with them in separate boxes

Disposal of the packaging material in accordance with local regulations.

4. Function

The FVS-600 unit is a CO₂-controlled façade ventilation device ready for installation for local ventilation and venting directly through the façade, with

- direct façade connection, incl. outside/outlet air
- weather protection grids with aerodynamically separated exhaust routing
- highly efficient silencer for supply and exhaust air
- heat recovery and controllable secondary air operation, without after heating of the supply air in the unit.

Installation under ceilings, suitable both for visible installation and for integration into a ceiling cassette.

Low danger of freezing of the heat recuperator by control of the supply air temperature via secondary air addition.

No de-icing from electrical pre-heating of the outside air required.

The outside air flow is cleaned through an fine dust filter class ISO ePM1 80 % (formerly F8/F9) and heated to the target supply air temperature by a cross-counter-flow heat exchanger at low outdoor temperatures. When the supply air temperature rises, the supply air temperature controller opens the bypass flap. Part of the outside air flow bypasses the heat recuperator and thus reduces the supply air temperature in order to cool the room.

A compact, highly efficient double silencer for supply and exhaust air seals off the ventilation unit on the room side. Formed parts in the air ducts that are connected to the silencer permit line-bound air guidance with supply and exhaust air diffusers without short circuiting the flow.

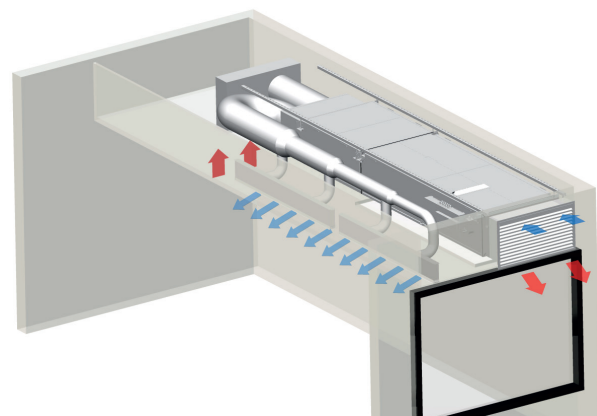

Function

4.1 Controller operational mode

Automatic mode

The standard is operation according to CO₂ -demand. If the factory-set CO₂ threshold is exceeded the ventilation will come on automatically.

If the factory-set CO₂ threshold is undercut, ventilation stops (threshold may be changed through parameter setting).

The system works independently without need of any further operating elements.

Inputs for activation (see chapter 6.4)

A bridge is placed at the input D1 to M in the factory. The device works without connection of a CO₂ sensor in permanent operation in operating mode "Com", conveying 600 m³/h air.

The following four inputs may be used for a central or decentralized activation on site via button. The factory-side bridge between the terminals D1 and M then must be removed.

1. DI 1 Ventilation mode „Com“ (factory-side bridge)

Mode activation with 100 % nominal flow rate (factory-set to 600 m³/h, nominal value parametrizable). Ventilation starts if the CO₂ threshold is exceeded (see CO₂-controlled operation). With no CO₂-sensor connected the unit will operate continuously (mode „Com“, independent of CO₂ value).

The operating modes „Com“ und „Eco“ are only released by the device when:

- the exhaust air temperature (room air temperature) is higher than the set parameter „Limit AB“ = +15 °C (factory-side)
- the CO₂-concentration in the room exceeds the threshold (at CO₂-controlled ventilation mode, target values CO₂ „Com“ or „Eco“ SW-ON = 1000 ppm)

2. DI 2 Ventilation mode „Eco“

Mode activation with 50 % nominal flow rate (factory-set to 400 m³/h, nominal value parametrizable). Ventilation starts if the CO₂ threshold is exceeded (see CO₂-controlled operation). With no CO₂ sensor connected, a bridge must be placed at the input D2 to M. The unit will operate continuously in „Eco“ mode.

3. DI 5 Forced ventilation

If in the „Eco“ or „Com“ modes „forced ventilation“ has been activated, the CO₂ level inside the room will be ignored. Please note: Ventilation will continue until “forced ventilation” is deactivated or the mode of operation changed. The operating modes “Eco” and “Com” are only released by the unit when the exhaust air temperature (room air temperature) is higher than the set parameter “Threshold AB” = +15°C (factory-side).

4. DI 3 Night ventilation

In summer, discharge of the heat stored in the room during the day can be supported by the operating mode night ventilation. Night ventilation is only released by the unit when the following conditions are met:

- The exhaust air temperature exceeds the set threshold (parameter „AB target“ = +19 °C factory side). If the exhaust temperature drops below the set value, night ventilation is deactivated. Deactivation of night ventilation protects the room from cooling out.
- The temperature difference between supply air and exhaust air sensor exceeds the set parameter (parameter „Δ ZU/AB = 2 K factory-side)
- the minimum permitted supply air temperature is reached (parameter „ZU_{min}“ = +5 °C factory-side)

If the operating mode night ventilation is switched on, the unit will check the existing conditions for approx. 10 min (parameter „Kick duration“ = 10 min in the factory settings). If this inspection is not successful, the operating mode night ventilation is paused for a certain time (parameter „Kick pause“ = 80 min in the factory settings). Then the unit will check the conditions again.

If inspection is successful, the unit continues to run until one of the above conditions is violated or the operating mode is changed.

Night ventilation must not be used in winter, in order to prevent cooling out of the rooms. If night ventilation is used in winter anyway, it is possible for the room to cool down to the limit of the exhaust temperature T_{AB} = 15 °C. If this value is undercut, the device will switch off and a malfunction message will be issued. The duration of the kick phase and kick pause may need to be adjusted to the situation on site.

For system-related reasons, heating of the outside air on the way to the room cannot be avoided. This effect must be considered in design of the night ventilation and varies according to structure of the ventilation system.

Function

Continuation 4.1 Controller operational mode

Other modes on site

(factory-side bridge between D1 and M may need to be removed):

- Manual on/off switch, selection of mode level; prolonged operating times due to „not switching off“ may be avoided by fixed operating times or central, scheduled cutoffs; after switching off a ventilation followup time is recommended to provide initial air quality. In schools, unauthorized manipulation must be avoided. It might not be possible to protect operating units against vandalism.
- Central activation of fixed & scheduled operating times
- Local Timer program (ZSP) on each unit
- Presence detector
With power-up delay and fixed operating time; cuts off if time has elapsed without presence signal (designed flow rate).
- Central control by GLT via a bus system (KNX S-mode, BACnet, LON, Modbus-RTU (slave)). A list of the values that can be read/overwritten is available from LTG Aktiengesellschaft.

Temperature control

The FVS-600 unit is not designed for controlling the room temperature. It is equipped with a supply air temperature control and a fixed target value (factory setting: 17 °C). Secondary air is added in order to prevent dropping to below the target value (see frost protection).



The room heating must take care of re-heating to the target value of the room temperature by the corresponding sizing.

Anti freeze

FVS-600 unit without re-heater avoids freezing of the heat recuperator by additionally monitoring the exit air temperature. If the exit air temperature drops below a defined temperature, secondary air will be added.

Condensate

Under certain operating conditions condensate formation may be impossible to avoid due to high heat return. The unit is provided with a condensate drainage system to be connected on site with the required slope or via pump. Use a flexible condensate connection.

LTG system unit for operation without additional condensate drain (optional)

Intelligent control means a condensate drain can be dispensed with.

Emergency shutdown (fire protection)

In case of a power failure, the outside airdamper will automatically shut off the outside air and exit air opening via spring return drive (running time 20 secs). In case of a fire in the building, all units may be shut off at the fire alarm centre. The circuit may also be interrupted by smoke detectors.

Lead and follow-up times

When turned on, the unit will be operated for a parametrizable lead time (factory-set to 60 secs) with the outside air and heat recovery bypass dampers closed before control obtains clearance. After 150 secs the outside air damper is 100 % open. When turned off, the unit is operated in the above condition for a parametrizable follow-up time (factory-set to 180 secs) in order to allow humid filters and heat recoverers to dry.

Function

Continuation 4.1 Controller operational mode

Malfunction indicator

The controller comprises of a malfunction indicator input in terms of a group alarm which is switched if the following occurs:

- Exhaust air temperature below limit
- Supply air temperature sensor fracture
- Exit air temperature sensor fracture
- CO₂ sensor without signal, if connected

The malfunction message must be acknowledged to confirm elimination of the problem (see chapter 7.2 „alarm, malfunctions“).

Parametrization via HMI module (Human Machine Interface)

Via service tool HMI the set operating modes, and set-points may be indicated. Having entered your password you may also use the service tool HMI to change control parameters (after consultation with the manufacturer).



CO₂-controlled ventilation („Com“ und „Eco“)

Once the central ventilation mode has been activated, the ventilation is started whenever a preset programmable CO₂ level (factory-set to 1000 ppm) is achieved and again switched off when a lower preset limit (factory-set to 800 ppm) is reached. The ventilation mode uses a continuous outside air flow, depending on activation based on DI 1 or DI 2 with full load or partial load flow rates (with programmable levels). One or several window contacts may be connected to the factory-bridged connections M-D4 (N/C contact) and will disconnect the unit as soon as the window is opened (follow-up time).

Manual operation of ventilation mode

No CO₂ sensor connected. The unit is switched on/off via button at „Com“ or „Eco“. Longer, uncontrolled running times due to forgotten switch-off may be avoided using central switch-off. Manual operation is not a standard operating mode, therefore parametrization is required.

4.2 Intended use

The decentralized ventilation unit type FVS-600 has been designed exclusively for use in indoor rooms.

It is approved for ambient temperatures of +5...+40 °C with a maximum relative humidity of 90 % (non-condensing).

In order to ensure safe motor functioning the ambient temperature when installed should not exceed +40 °C.



Any other operating conditions require the express and written permission of LTG Aktiengesellschaft.

LTG Aktiengesellschaft does not assume responsibility for any damages resulting from unintended use.

Function, Technical Data

4.3 Notes for users

Operation of the FVS-600 unit with CO₂ sensor

The unit switches on self-operated when the specified CO₂ -activation concentration is reached; depending on room size and occupation density this is 10...20 minutes after lessons start.

The unit switches off when the specified deactivation concentration is reached, i.e. it lags for 10...20 minutes during breaks or after the end of lessons.

Ventilation and room temperature

The ventilation unit works independently from the room heating. Control of the room temperature requires a room heating system! The supply air is adjusted to a fixed temperature of +17 °C via the heat recovery during the heating period. This colder supply air flow is necessary to prevent rising of the room temperature through the person heat. If there are few persons, the room heating must ensure the desired room temperature of, e.g., +21 °C using the thermostat valves.

The FVS-600 unit does not switch on below a specified room temperature of, e.g. +15 °C (cooling protection).

At outdoor temperatures > +17 °C, the supply air temperature will increase as well. Without mechanical re-cooling (cold water circuit required) the room temperatures may slide above the outdoor temperatures due to the heat load from persons and the sunlight.

Room temperatures in summer can be limited by the following measures:

- Use external sun protection in time and consistently
- Use the night ventilation via the unit or by window ventilation in summer
- Ventilate via the windows at the same time at low outdoor temperatures. The FVS-600 unit switches on automatically when the room air quality drops.

Mechanical and free ventilation

At outdoor temperatures above +15 °C, tilted windows can be used for concurrent ventilation. When no window contact is connected, the FVS-600 unit will switch off on its own at good room air quality and thus save power.

5. Technical data

5.1 Technical data ventilation unit (type FVS-600/DI, type FVS-600/S)

| | | | Operating mode: | Eco | Com | Com | Com* |
|--------------------------------------------------------------------------------------------------------|---------------------------|---------------------|--------------------------|-----|-----|-----|------|
| Bypass | V | [m ³ /h] | | 400 | 600 | 700 | 730 |
| Radiated noise | L_{WA,1} | [dB(A)] | FVS-600/DI, .../W | 31 | 37 | 39 | 40 |
| | | | FVS-600/S | 33 | 39 | 41 | 42 |
| Housing radiation | L_{WA,2} | [dB(A)] | FVS-600/DI, .../W | 36 | 42 | 44 | 45 |
| | | | FVS-600/S | 41 | 47 | 49 | 50 |
| Resulting sound pressure level in the room | L_{WA,1+2} | [dB(A)] | FVS-600/DI, .../W | 25 | 31 | 33 | 34 |
| | | | FVS-600/S | 30 | 36 | 38 | 39 |
| Radiation at the weather protection grille | L_{WA,3} | [dB(A)] | FVS-600/DI, .../W, .../S | 51 | 61 | 65 | 66 |
| Radiation at the weather protection grille with intermediate duct piece L = 500 mm, incl. SD | L_{WA,3} | [dB(A)] | FVS-600/DI, .../W, .../S | 45 | 55 | 59 | 60 |
| Electrical power consumption | P_{el} | [W] | FVS-600/DI, .../W, .../S | 50 | 130 | 205 | 235 |

* Max. possible flow rate in the „Com“ mode. This application is possible using an internal program adjustment.

L_{WA,1} Sound power level of radiated noise at the sound absorber outlet for supply air and exhaust air, with 3 dB absorption via diffusers

L_{WA,2} Sound power level of emission via casing, 3 dB sound absorption via ceiling panelling (not applicable for visible installed units)

L_{WA,3} Sound power level on the outside of the weather-protection grille for outside air and exit air, without sound absorber

With average room absorption D₁ = 12 dB and damping and absorption D₂ = 3 dB in the ceiling panelling.

Example for 600 m³/h:

$$\text{Sum level } L_{WA,1} + L_{WA,2} = 43 \text{ dB(A)}$$

$$\text{Sound pressure } L_{pA,1+2} = 43 \text{ dB} - 12 \text{ dB} = 31 \text{ dB(A) inside the room}$$

Sound pressures L_{pA,3} of 4 units in the facade at a distance of 10 m in front of the weather protection grille (free field) with absorption D₄: L_{pA,3} = L_{WA,3} - 28 dB.

Example for 600 m³/h with sum level 6 dB and distance absorption 28 dB:

$$L_{pA,3} = 61 + 6 \text{ dB} - 28 \text{ dB} = 39 \text{ dB(A) outside}$$

Technical Data

5.2 Technical data re-heater

To ensure 100 % outside air operation even at very cold outdoor temperatures, a re-heater must be provided. This will re-heat the supply air to the supply air target value (+17 °C). This ensures that no room air is added to maintain the temperature. The re-heater must be installed between the silencer and the connection duct.



When using a re-heater, the supply air temperature sensor must be placed in the air direction behind the re-heater! The re-heater function must be activated at the controller during commissioning!

- The re-heater weighs 35 kg.
- The re-heater is designed so that 100 % outside air operation is warranted even at an outdoor temperature of -25 °C, a water mass flow rate of 100 kg/h, and a lead temperature of at least +40 °C.

Water-side pressure loss for different water mass flow rates

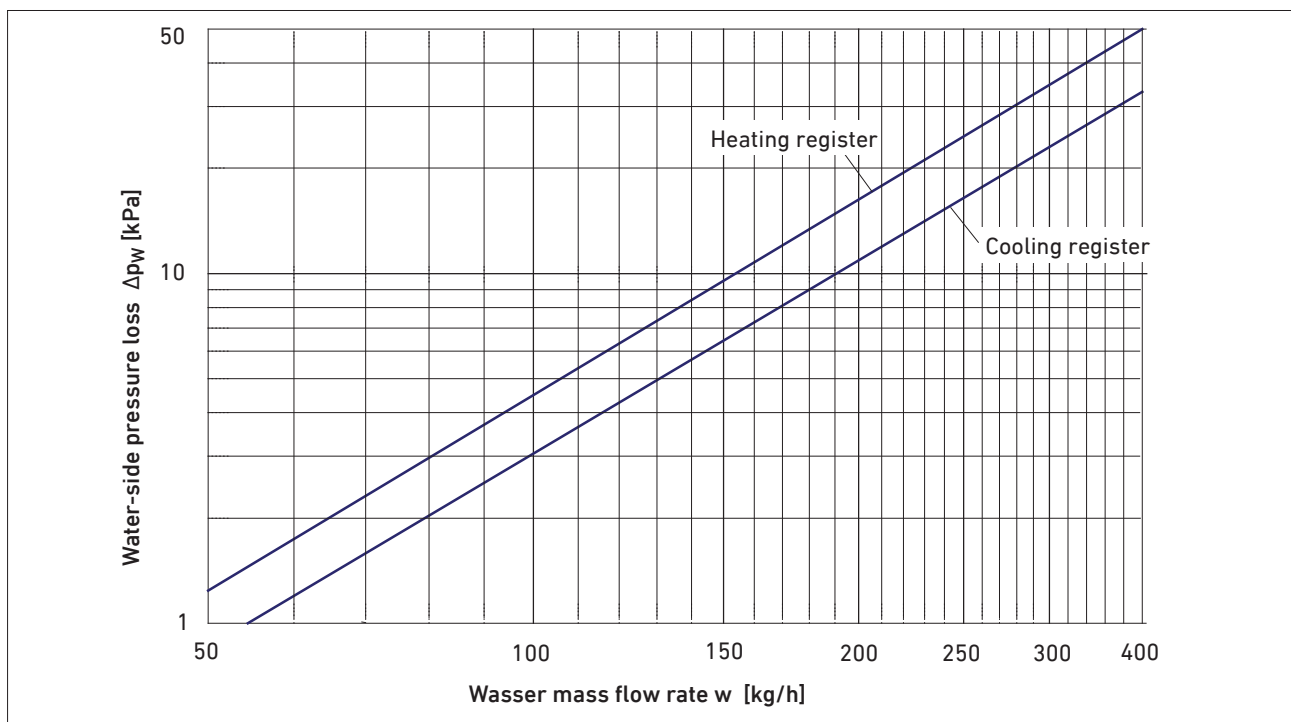

Technical Data

5.2.1 Re-heater with water (for type FVS-600/DI, optional)

| | |
|-----------------------------------------------------------------------------------------------------------------|---------|
| Necessary reheating capacity (with -15 °C outside air temperature, $V_{nom} = 600 \text{ m}^3/\text{h}$) | 1600 W |
| Nominal water mass flow rate | 80 kg/h |
| Pressure loss with nominal water mass flow rate | 4.7 kPa |
| Nominal water inlet temperature | 40 °C |
| Weight | 35 kg |

The chart refers to the following values:

| | |
|--------------------------------------|-------------------------|
| Relative humidity of the exhaust air | = 25 % |
| Relative humidity of the outside air | = 90 % |
| Exhaust air temperature | = 22 °C |
| Nominal flow rate | = 600 m ³ /h |

The relative humidity strongly influences the heating output. Therefore, this chart can only be viewed as an example. Other conditions must be designed project-specifically.

The re-heater is sufficiently dimensioned for the necessary heating capacity to be assured even at low inlet temperatures.

Required heating capacity depending on outside air temperature (with 17 °C supply air temperature)

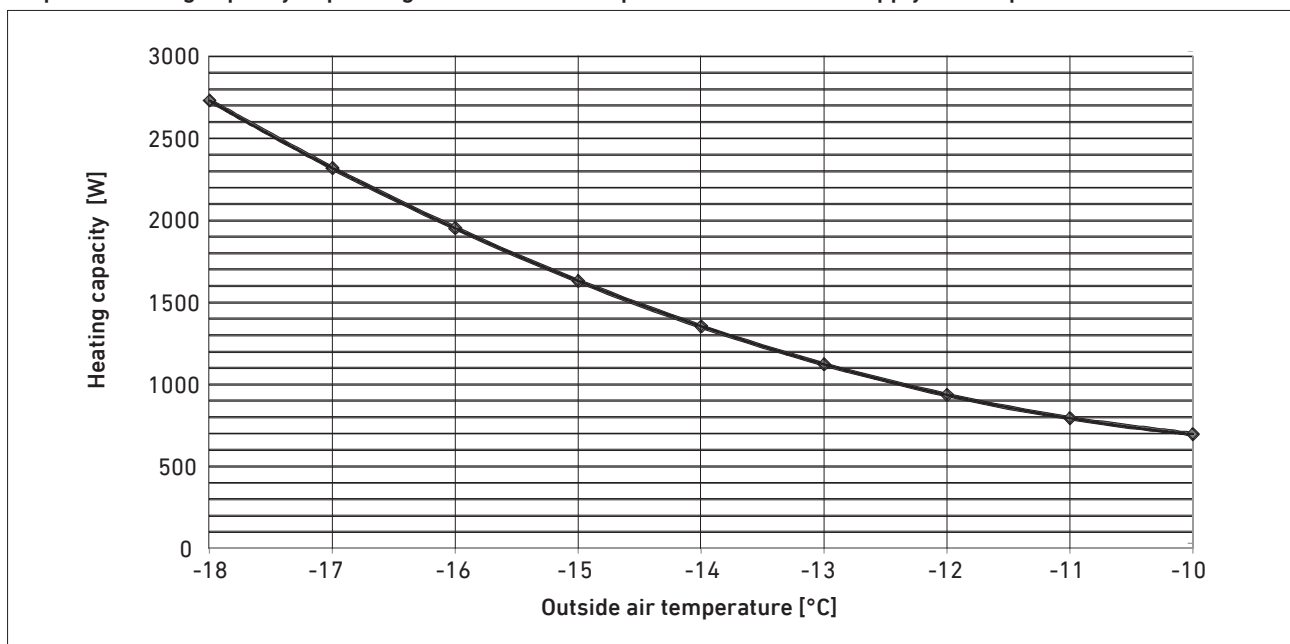

5.2.2 Electric re-heater (for type FVS-600/DI and FVS-600/W, optional)

| | |
|----------------------------------------------------------------------------------------------------------|----------------|
| Necessary reheating capacity (with -15 °C outside air temp, $V_{nom} = 600 \text{ m}^3/\text{h}$) | 1600 W |
| Voltage | 230 V AC |
| Capacity | up to 4 kW |
| Control input | 0 (2)...10 VDC |
| Operating with continuous signal | |
| Temperature control TW with automatic RESET | 75 °C |
| with manual RESET | 95 °C |

Air flow control

Reach-in prevention grille at inlet and outlet

Installation by insertion into the supply air duct

Technical Data

5.3 Technical data cooling register (optional)

5.3.1 Re-cooler with water (for type FVS-600/DI, optional)

Necessary after-cooling capacity

sens. cooling capacity 3000 W

total cooling capacity 4800 W

(with 32°C outside air temperature,
 $V_{nom} = 600 \text{ m}^3/\text{h}$, $T_{supply \text{ air}} = 17 \text{ °C}$)

Nominal water mass flow rate 250 kg/h

Pressure loss with
 nominal water mass flow rate 16 kPa

Nominal water inlet temperature 6 °C
 (condensing operation)

Required cooling capacity depending on outside air temperature (with 17 °C supply air temperature)

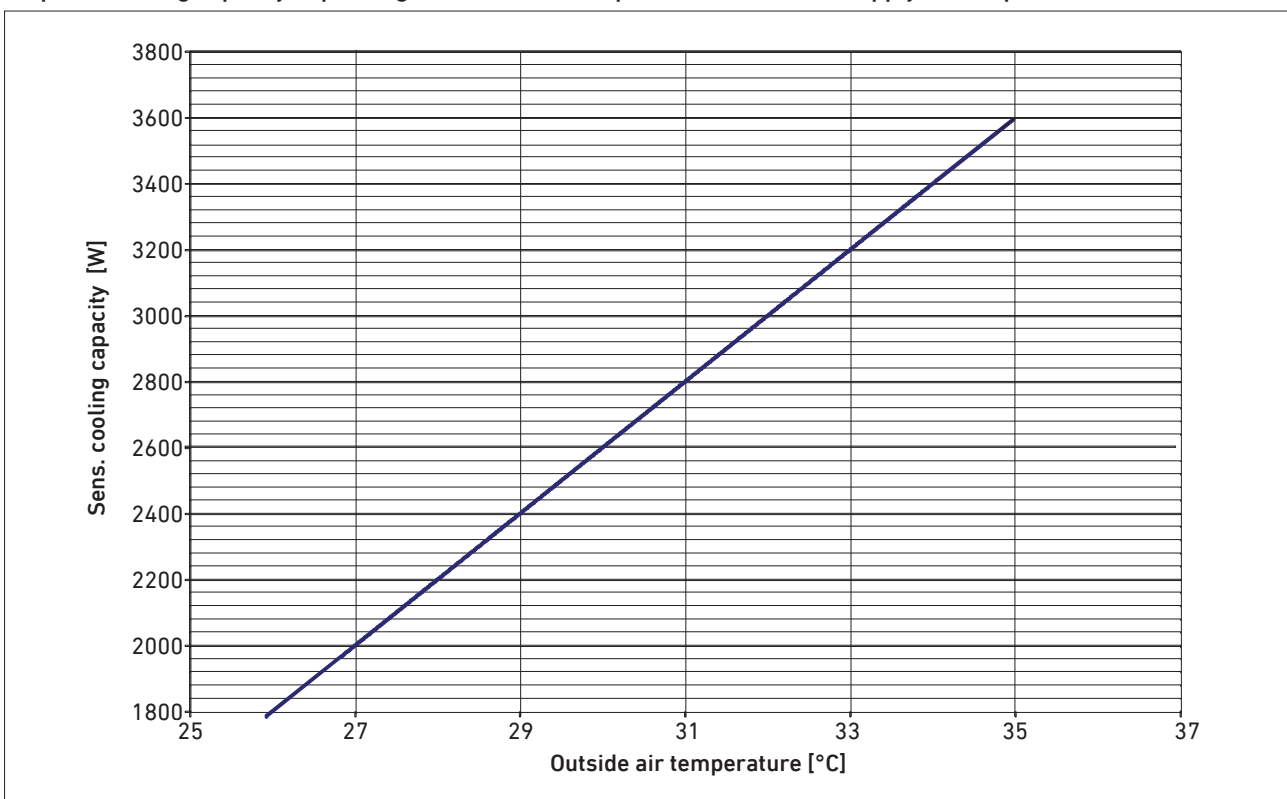

Installation

6. Installation

6.1 Installation notes

Safe transport and professional suspension requires a forklift and an industrial truck. The forks of the lifting device must be sufficiently wide to safely position the FVS-600 unit without damage to the bottom. The 3 lower service covers are only installed after the unit is suspended.

The following are enclosed for installation (per unit):

- 1 x seal for transfer piece (Softpad) „unperforated“
- 2 x seal transfer piece 10 mm (Softpad) „perforated“
- 8 x damper element 24 x 8.5
- 22 x hexagon screw M8 x 40 DIN 933 galvanised
- 2 x holder for temperature sensor
- 10 m mounting rails
- 10 x vibration damper PVC for M8
- 10 x nut, sliding nut for suspension
- 42 x washer DIN 9021 galvanised
- 28 x hexagon nut M8 DIN 934 galvanised
- 3 m threaded rod M8 x 1000 DIN 976 galvanised
- 2 x cyl.-screws, hexagon socket M4 x 12 DIN 912 galvanised
- 4 x washer DIN 125 galvanised
- 2 temperature sensor Ni 1000 LG 6 m cable
- 4 x cyl.-screws, hexagon socket M5 x 16 DIN 912 galvanised
- 2 x hexagon nut DIN 934 galvanised

Requirements on site

- The weather protection grille has already been integrated in the facade according to manufacturer's instructions. Exit air must be able to flow freely downwards at about 45 degree. When in the outside air intake mode do not exceed a free cross-section related air speed of 2.5 m/s to keep rain from being sucked in. And take special care not to install any sun protection devices in front of the weather protection grille which might deflect the exit air stream and cause a short-circuit.
- On-site adapter duct(s) are installed (e.g. due to beams, for facade isolation).
- If the unit is to be installed in the intermediate ceiling, inspection openings and cutouts, if any, for the diffusers are to be provided (page 18).
- Allow sufficient lateral clearance to walls and ceiling linings for electrical connections (page 15 ff.).

6.1.1 Condensate tray and drain

The condensate tray of the ventilation unit has an „internal“ drop towards the condensate drain.

A removable siphon can be connected to the condensate socket. If there is not enough space, the odour trap can also be provided at the end of the drop line. The condensate connection must be flexibly performed.

At the condensate socket, the pressure is lower than the ambient pressure for 600 m³/h at
 exhaust air diffuser + M5-filter + heat recovery =
 (-20) + (-30) + (-80) = -130 Pa.

Therefore, a water provision of at least 15 mm WC is required.

Without odour trap, exhaust odours from the drainage system will be sucked into the exit air. The siphon must be filled with water before commissioning.

The holding volume of the condensate tray is approx. 4 l.

Installation

6.2 Suspension of the unit (general notes)



LTG Aktiengesellschaft is not liable for any contaminations of or damage to the device.

Do not apply any additional bores, screws or attachment elements to the housing of the unit. The unit can be damaged and impaired in function by this!

The unit must only be suspended by the intended attachment points!

When drilling in the ceiling, determine the position of power and water lines and observe them! Observe the loadbearing capacity of the ceiling and coordinate it with a structural engineer or architect if necessary!

The attachment elements must be dimensioned, inspected and installed according to the manufacturer's specifications!

6.2.1 Installation, general

The enclosed mounting rails must be shortened on site and fastened to the ceiling with approved dowels (permissible tensile load >2 kN) as specified by the person responsible for the project in accordance with the mounting sketches on page 15 ff.

The suspension from the longitudinal rail permits a crosswise alignment by +/- 5 mm. If this shifting scope is not sufficient, an additional cross member must be provided.

The FVS-600 unit and the compact silencer must be suspended horizontally from the 4 intended sheet steel angles.

For the connections on the façade side to the transfer line and on the room side to the silencer, the enclosed flange seals with structure-borne noise insulation must be used.

The screws embedded in a rubber sleeve must be tightened to a slight compression of approx. 1 mm. Force introduction into the façade must be avoided by professional suspension and alignment.

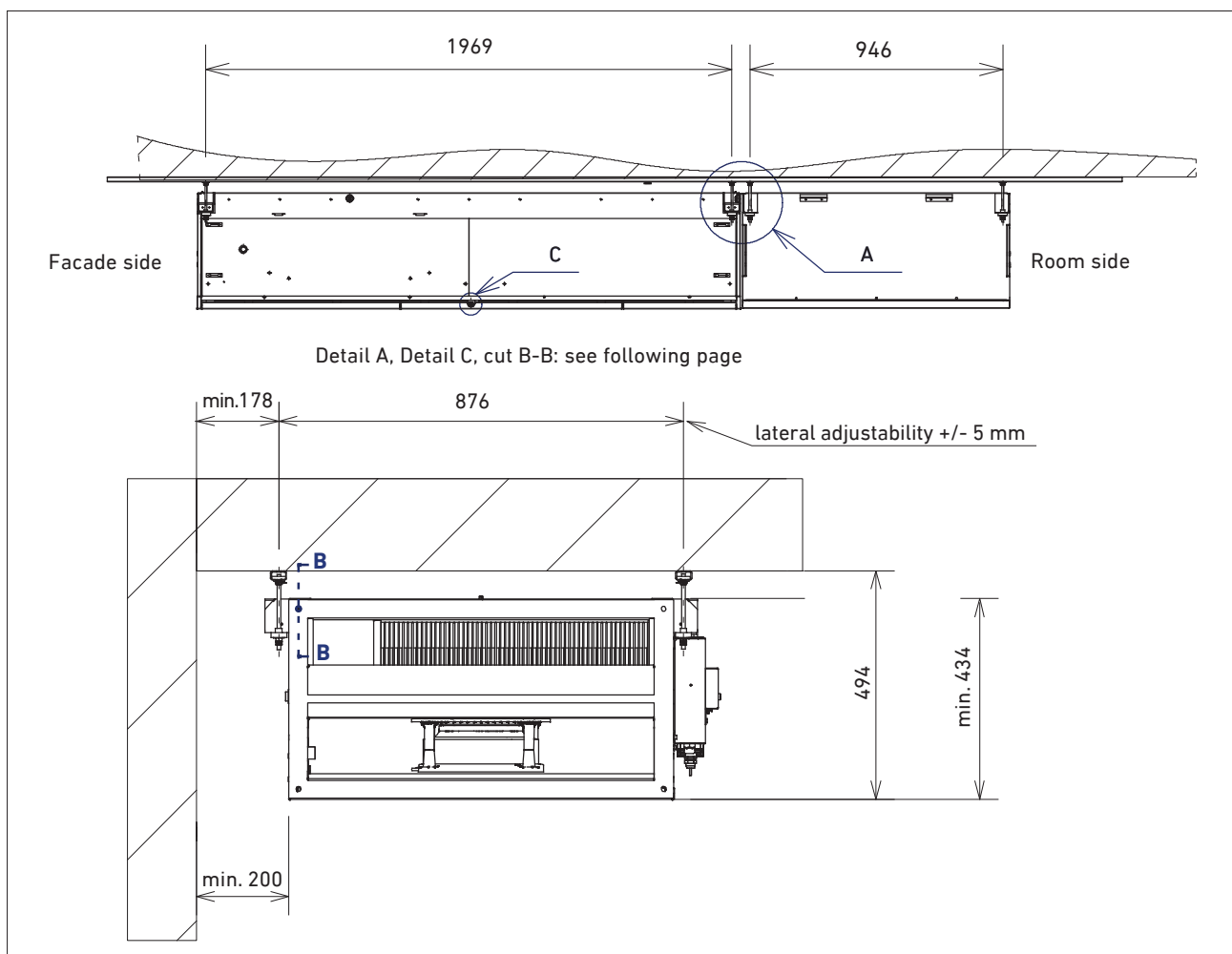

Installation

Continuation 6.2.1 Installation, general

Detail A

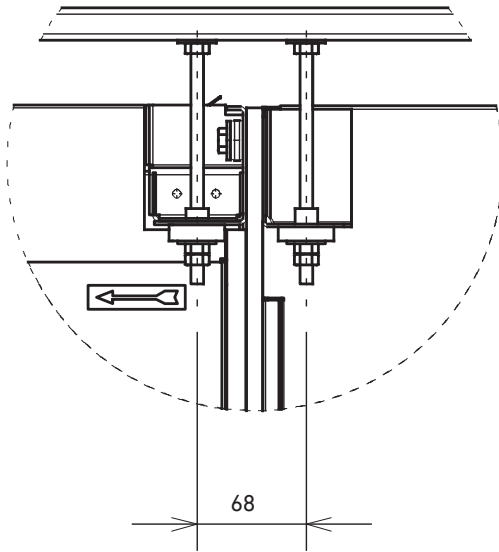

Detail C

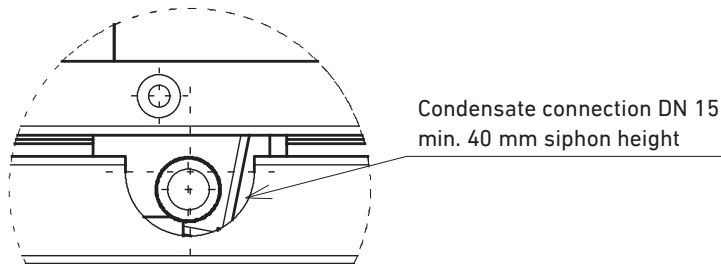

Cut B-B

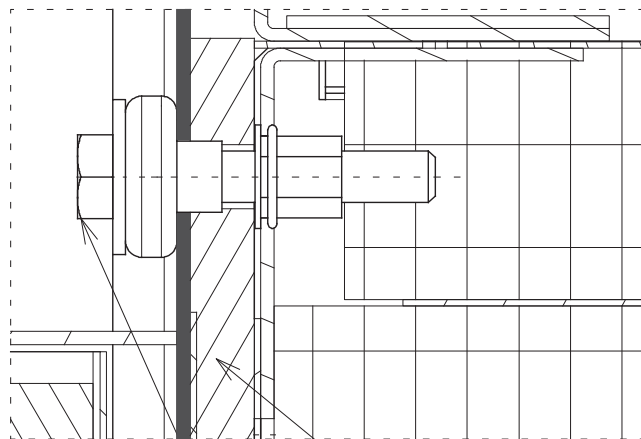

1 x washer, DIN 9021, $\varnothing_i = 8.4$ mm

1 x screw M8x40 DIN 933

1 x DÄMMGULAST® washer

sealing pad (perforated)

Installation

Continuation 6.2.1 Installation, general

Assembly drawing

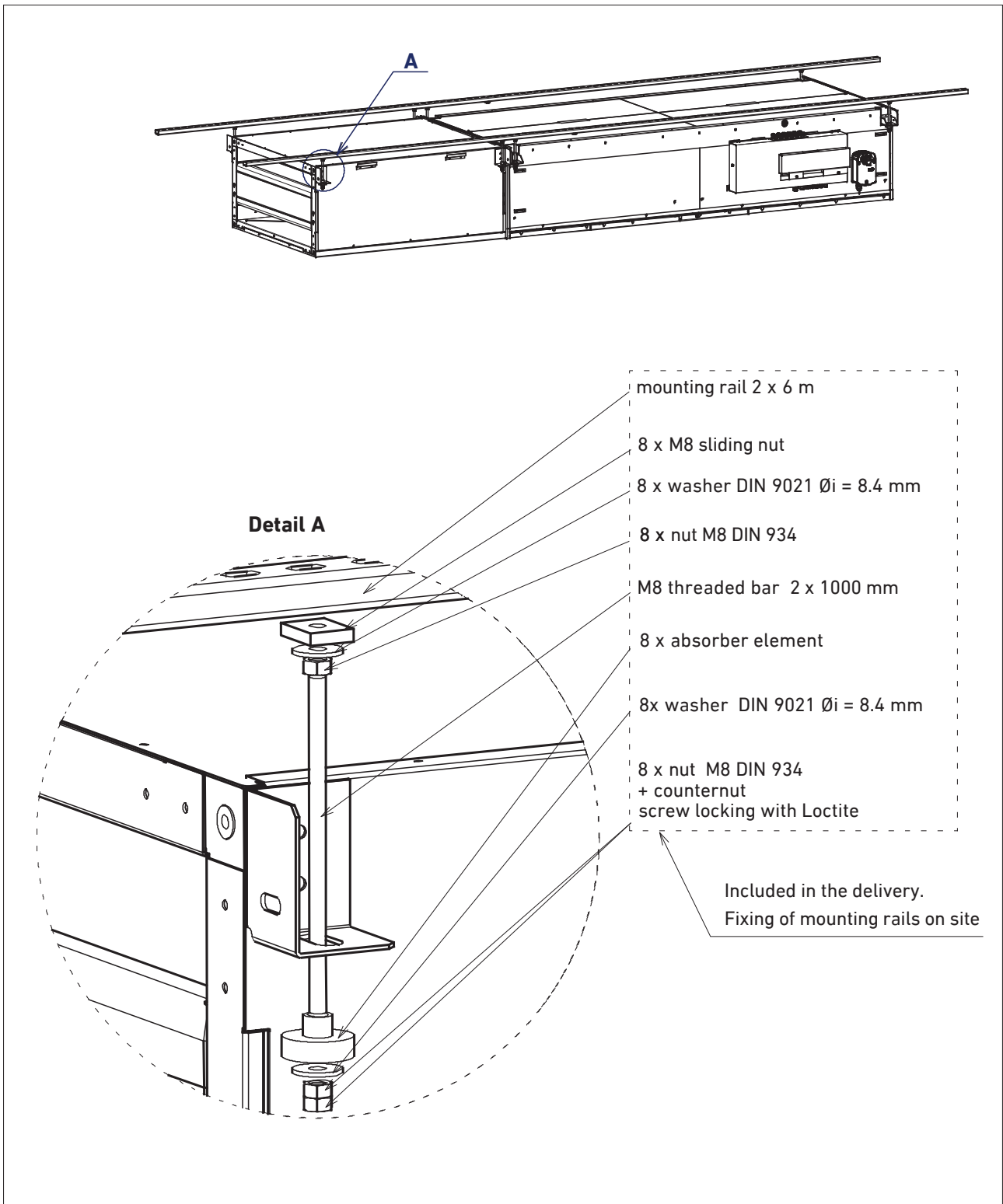

Installation FVS-600/DI

6.2.2 Installation of units type FVS-600/DI (integrated in ceiling panellings), with and without heat exchanger

The temperature sensors supplied loose are to be attached to the splitter silencer (supply air temperature) and in the exhaust outlet (exhaust temperature) in the intended clip holders (see assembly sketch).

The CO₂-sensor must be installed next to (not in) the exhaust passage. To apply the sensor cable, see electrical circuit diagram (see chapter 6.3).

Servicing capability must be ensured by service openings in the ceiling cassette, according to the drawing.

The following unit weights should be considered when suspended from the ceiling:

| | |
|---------|----------------------------------------------------------------|
| 13.5 kg | Weather protection grille with balancing line (10 inches long) |
| 170 kg | Ventilation unit |
| 112 kg | Sound absorber |
| 35 kg | Re-heater |
| 6 kg | Exhaust air diffuser with plenum and coarse dust filter |

Dimensions

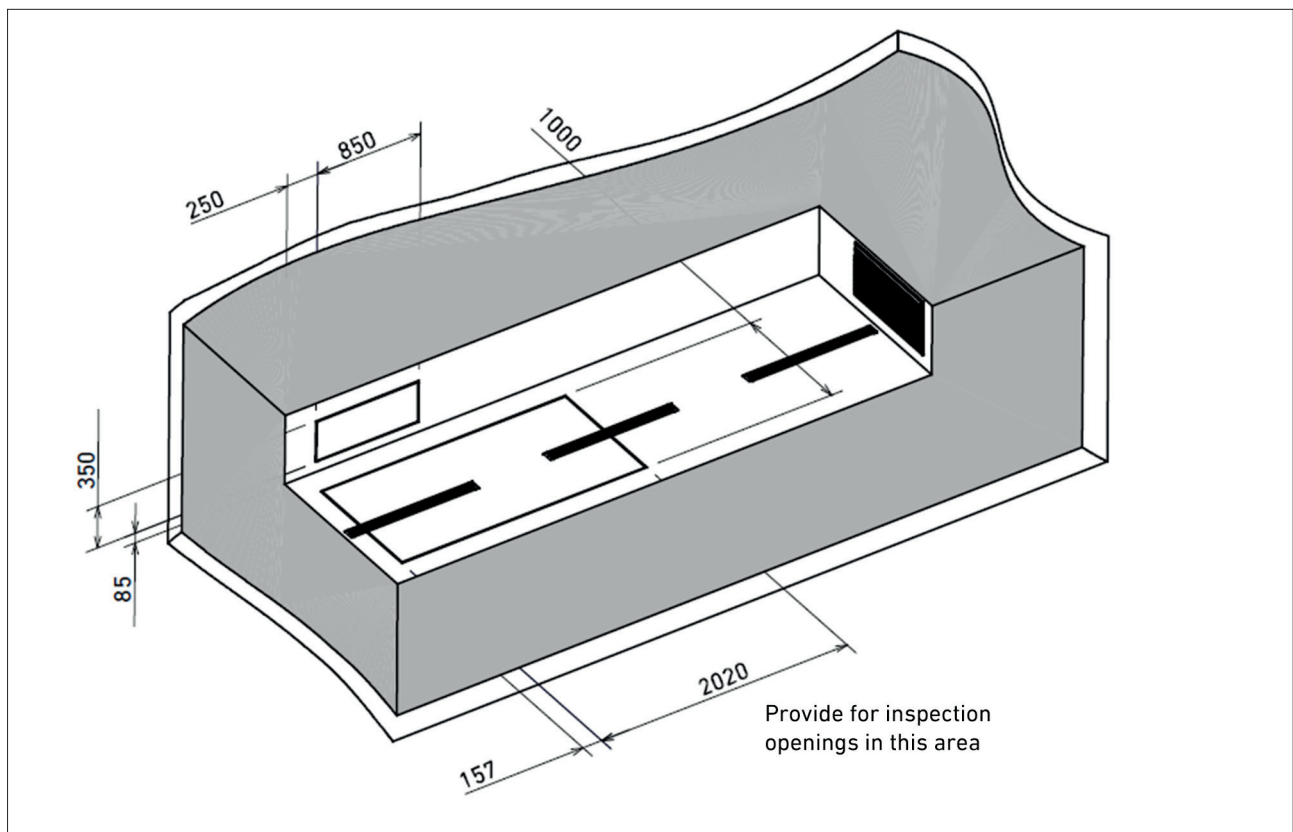

Continuation 6.2.2 Installation of units type FVS-600/DI

Installation of temperature sensor

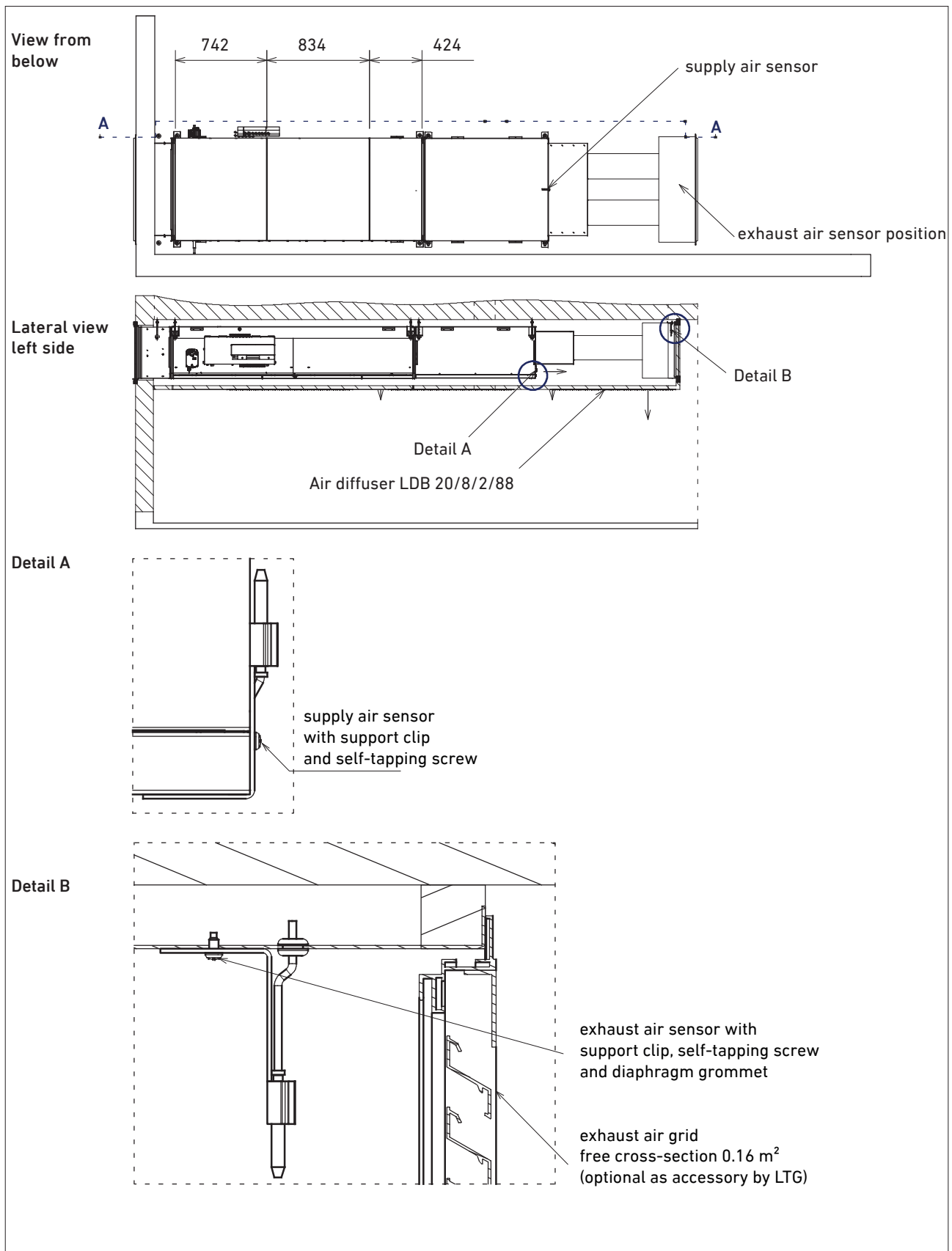

Installation FVS-600/DI

Continuation 6.2.2 Installation of units type FVS-600/DI

Exhaust air-side tubing, supply air via ceiling plenum

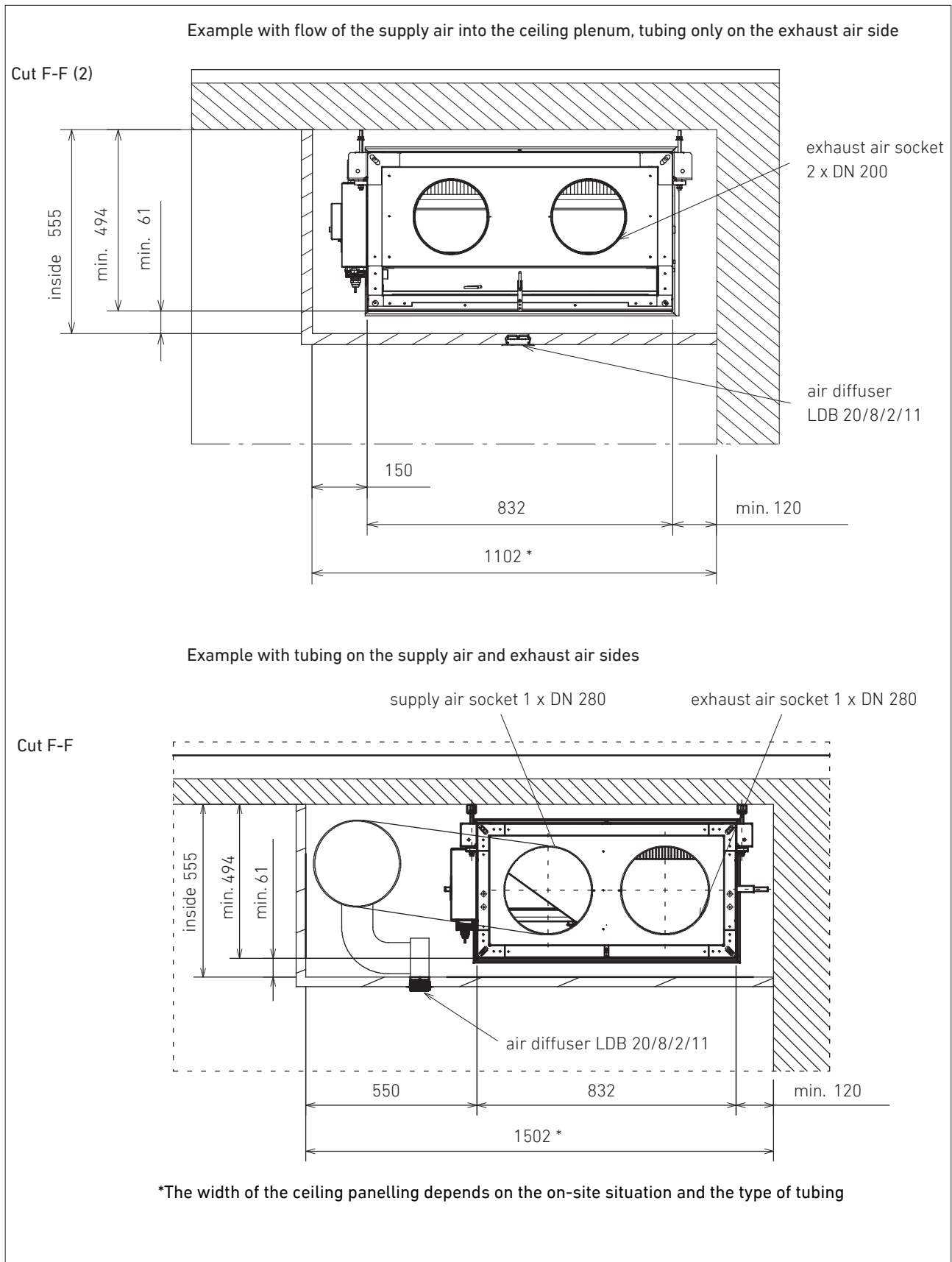

Installation FVS-600/DI

Continuation 6.2.2 Installation of units type FVS-600/DI

Connections (Re-heater optional)

Depending on the type of connection, the following options are available:

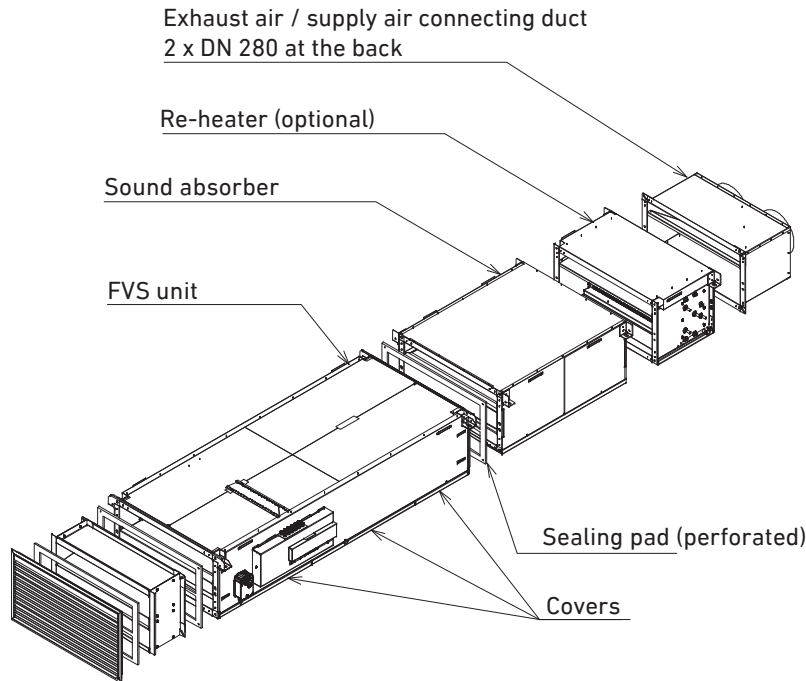

Connecting duct variants

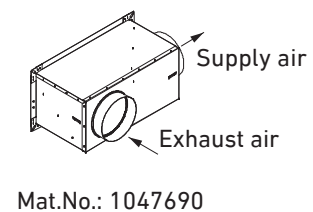
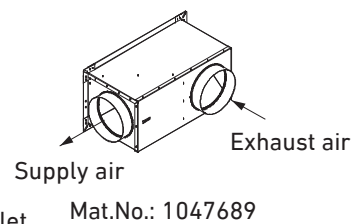
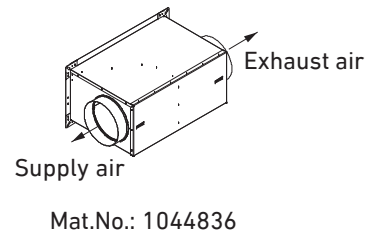
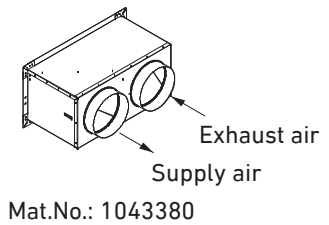
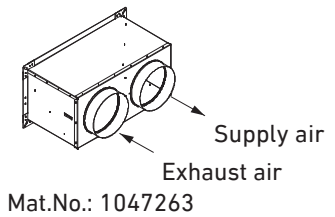

Shown with water connection on the left.
Hoses and valves for the cooling water circuit must be insulated up to the heat exchanger connection in order to prevent condensation!

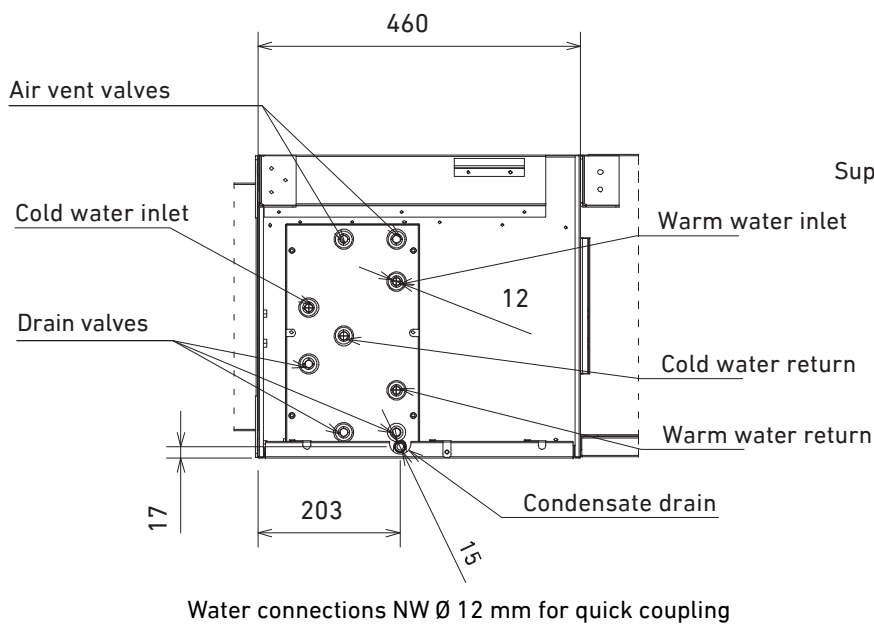

Installation FVS-600/W

6.2.3 Installation units type FVS-600/W (integrated in ceiling panellings, upright assembly)

Upright assembly opens up further installation possibilities, for example behind an intermediate wall. This variant is only possible with condensate supervision. The inspection openings should be distributed according to the drawings. On the side of the middle cover there must be no bars that might hinder the removal of the heat recovery unit.

As a supply air diffuser, the LTG air diffuser LW can for example be used for wall installation (types LW 20/8/2 or LW 20/8/3). The outlet rails must be installed over the full width of the ceiling panelling in the vertical wall surface, in cutouts to be made by others.

The adapter duct to the facade site can for example be provided using a DN280 adapter duct on the weather protection grille. The appropriate adapter sections on both the unit side and the facade side can on request be manufactured specifically for the project.

The following unit weights should be considered when suspended from the ceiling:

- 13.5 kg Weather protection grille with balancing line (250 mm long)
- 170 kg Ventilation unit
- 66 kg Sound absorber
- 35 kg Re-heater
- 6 kg Exhaust air diffuser with plenum and coarse dust filter

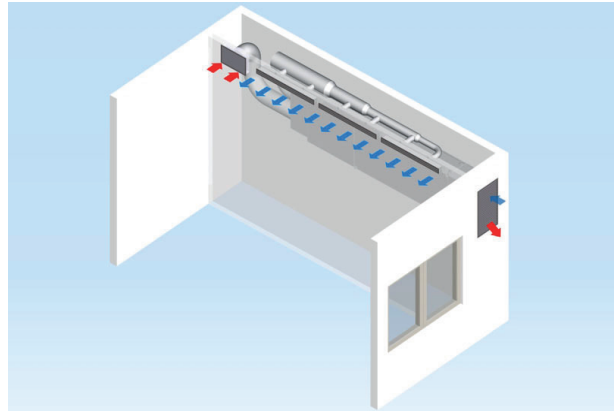

Installation FVS-600/S

6.2.4 Installation units type FVS-600/S (visible unit)

The following unit weights should be considered when suspended from the ceiling:

- 13.5 kg Weather protection grille with balancing line (250 mm long)
- 321 kg Ventilation unit incl. sound absorber and air diffusers

- Suspend FVS-600 unit with silencer from the ceiling as described in chap. 6.2.1.
- Execute electrical connections as described in chap. 6.4.
- Checking the installation as described in chap. 6.5.

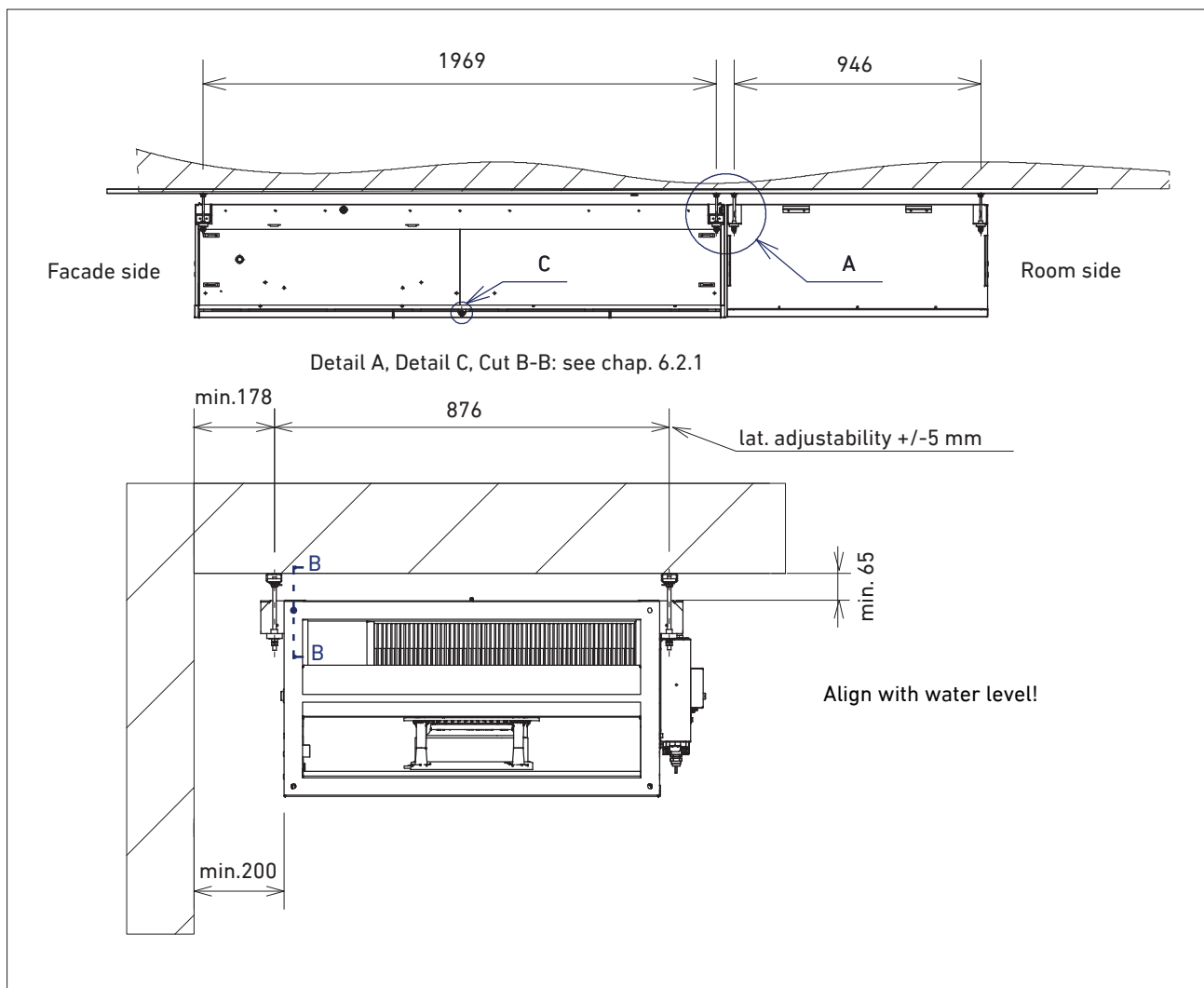
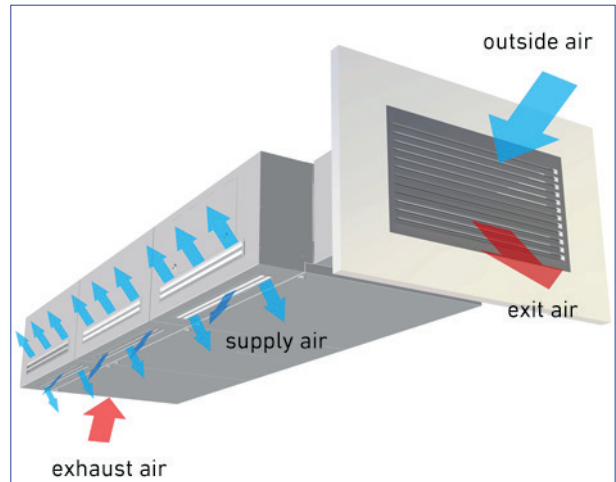

Installation FVS-600/S

Continuation 6.2.4 Installation units type FVS-600/S (visible unit)

Assembly steps

Step 1:

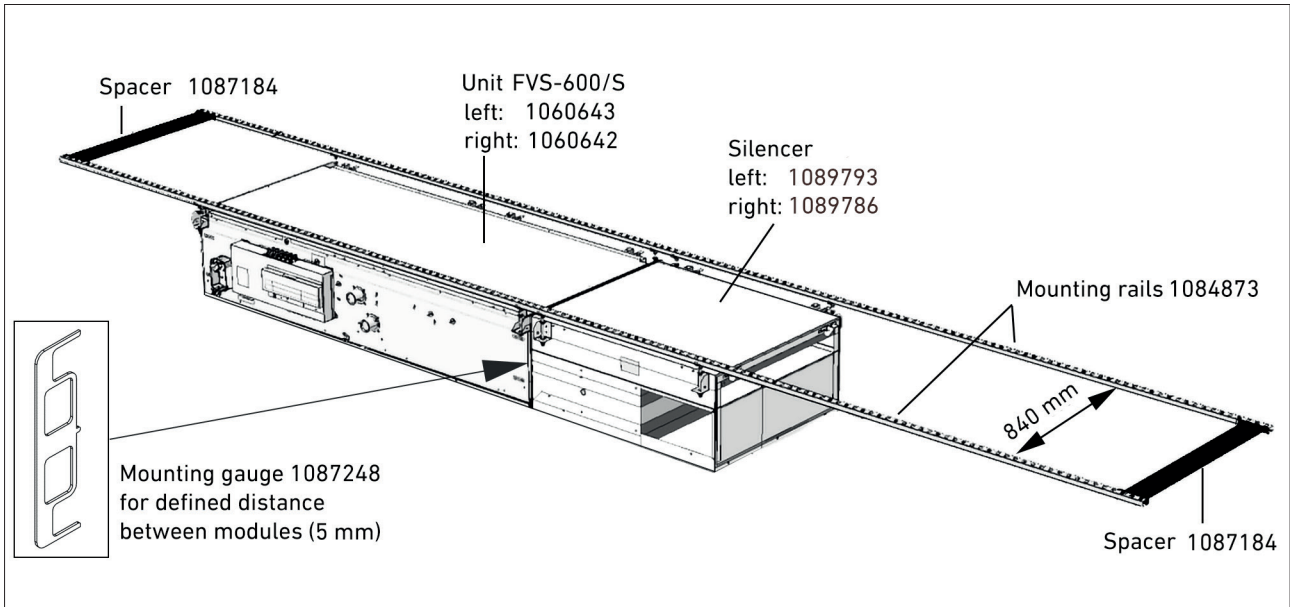

The spacers (1087184) included in the scope of delivery ensure exact alignment of the mounting rails and modules (FVS-600/S basic unit and silencer).

- Fasten the spacers to the mounting rails using 4 self-tapping screws 4.2x13 each.
- Mount the FVS-600/S basic unit and the silencer with the mounting gauge (1087248) for a defined distance.
- The visible panels are attached to the unit with additional mounting rails, see illustration under step 3.
- Partially preassemble threaded rods, see illustration on the right.

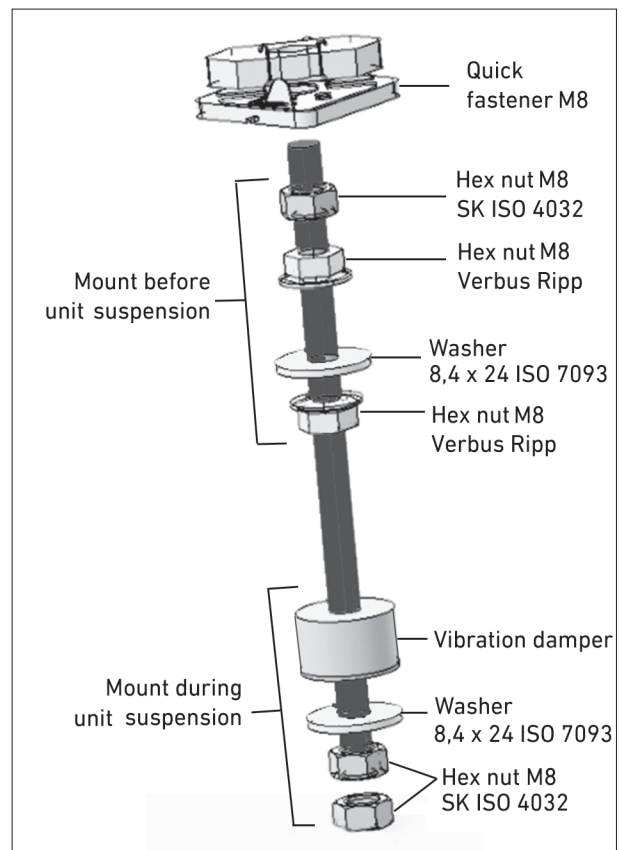

Installation FVS-600/S

Continuation 6.2.4 Installation units type FVS-600/S (visible unit)

Step 2:

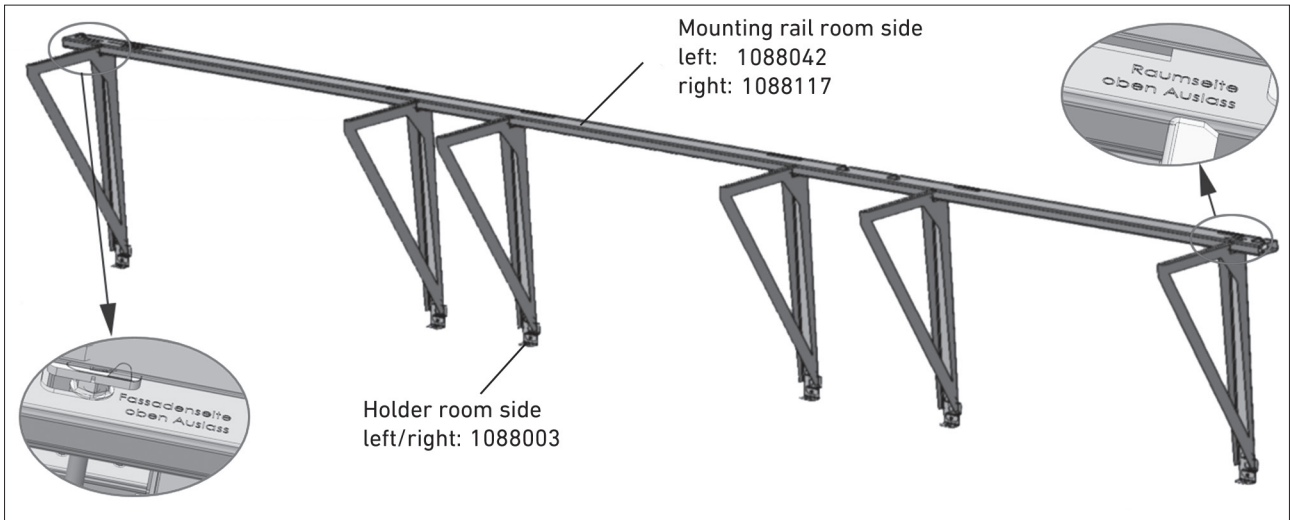

- Fasten 6 holders to the mounting rail on the room side using 2 pan-head screws M5x12 and 2 small washers M5 each (hole spacing 60 mm).

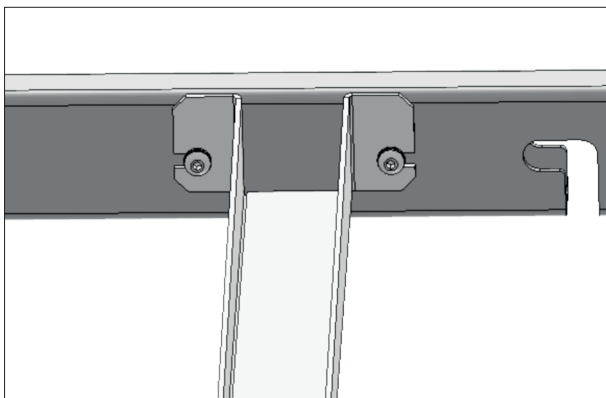
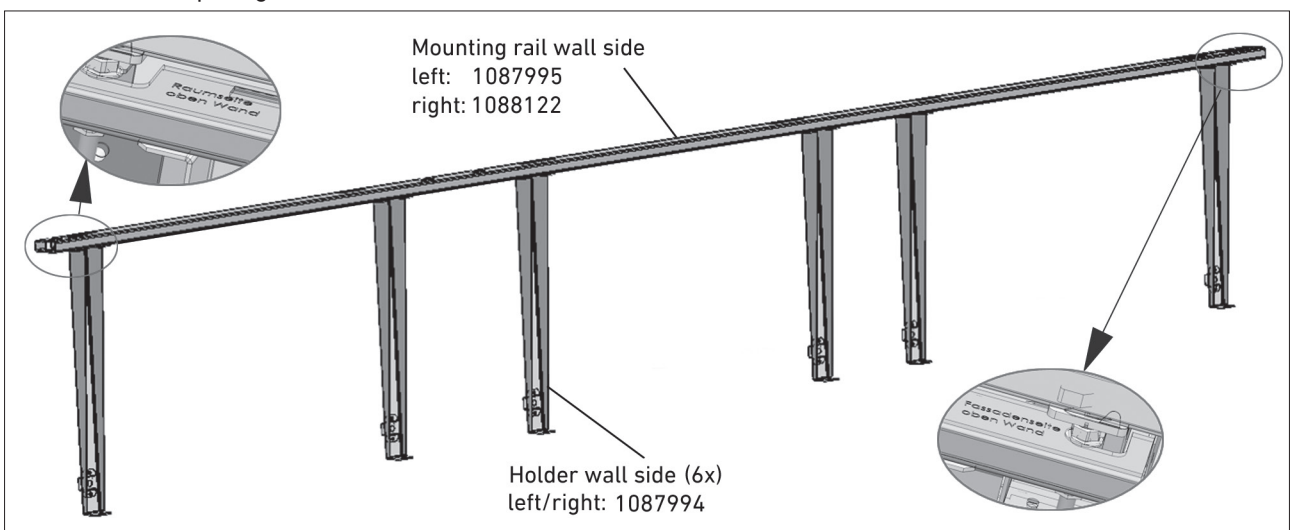

- Fasten 6 holders to the mounting rail on the wall side using 2 pan-head screws M5x12 and 2 small washers M5 each (hole spacing 70 mm).

Continuation 6.2.4 Installation units type FVS-600/S (visible unit)

Step 3:

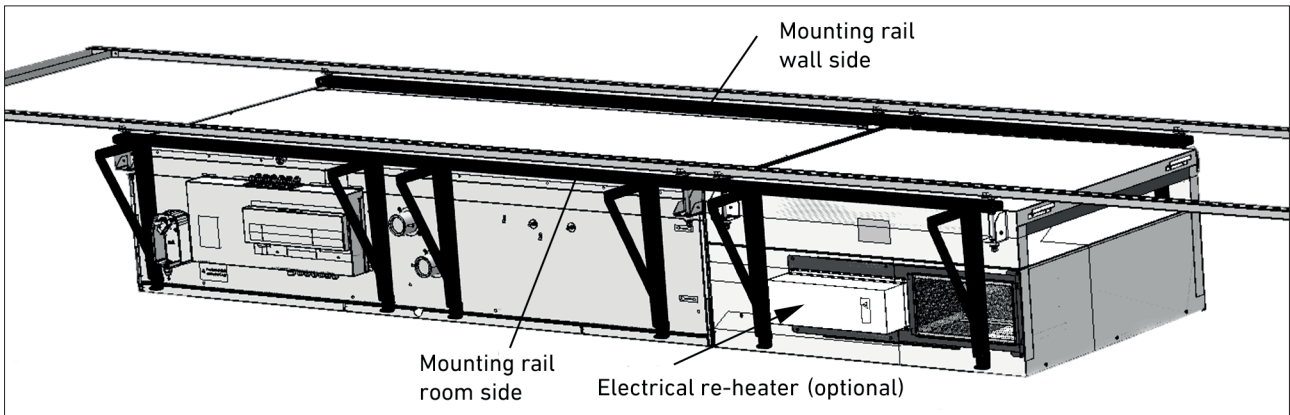

- Slide the mounting rails for the room-side and wall-side cover elements onto the threaded rods and fasten them. **Hang the mounting rail as close as possible to the top edge of the unit!**

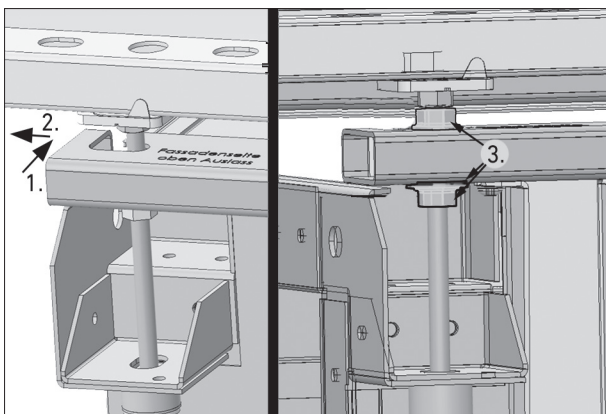

Mounting rail room side:

- Slide the rail onto the threaded rods (1).
- Move the rail in the longitudinal direction to the end of the slotted hole (2).
- Use M8 washer on lower nut (3).
Lock 2 nuts (M8 Verbus Ripp) (3) on rail.

Observe labels on mounting rail: "Fassadenseite oben Auslass" means "Facade side top diffuser". "Raumseite oben Auslass" means "Room side top diffuser".

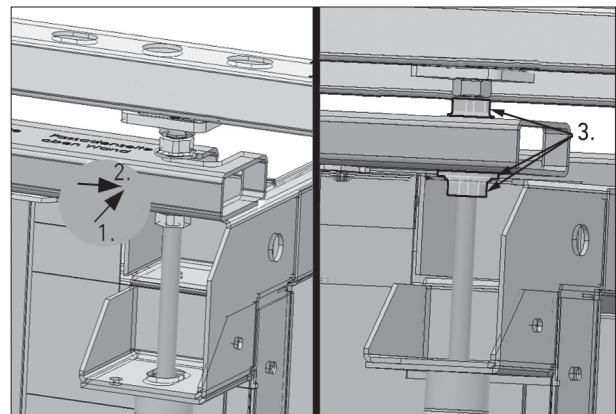

Mounting rail wall side:

- Slide the rail onto the threaded rods (1).
- Move the rail in the longitudinal direction to the end of the slotted hole (2).
- Use M8 washer on lower nut (3).
Lock 2 nuts (M8 Verbus Ripp) (3) on rail.

Observe labels on mounting rail: "Fassadenseite oben Wand" means "Facade side top wall". "Raumseite oben Auslass" means "Room side top wall".

Installation FVS-600/S

Continuation 6.2.4 Installation units type FVS-600/S (visible unit)

Step 4:

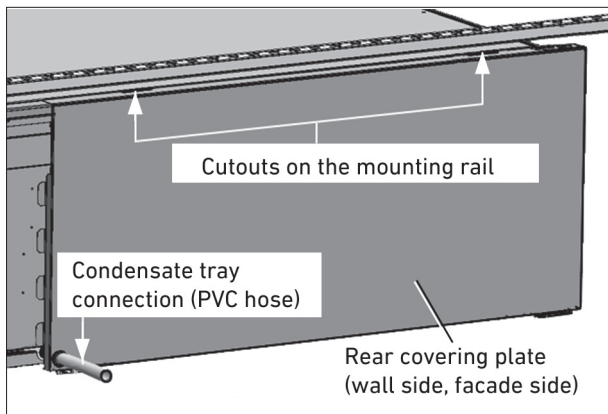

- Connect the PVC hose to the condensate tray connection and fasten it with the hose clamp. Guide the PVC hose through the rear covering plate (wall side, facade side)
- Insert the rear covering plate (wall side, facade side) into the cutouts of the mounting rail and align it with the front edge of the basic unit.

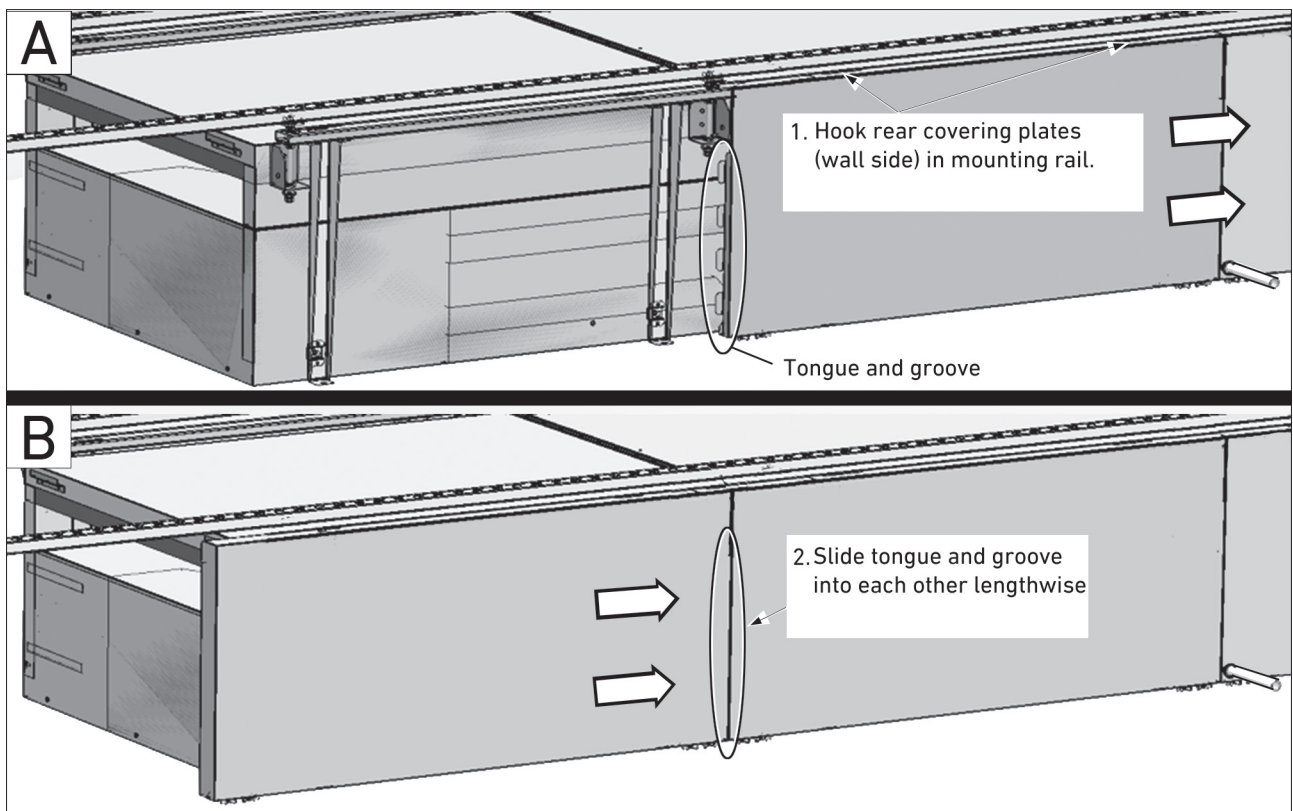

- Hook rear covering plates (wall side) into the matching cutouts of the mounting rail.
- Slide the tongue and groove into each other lengthwise.

Installation FVS-600/S

Continuation 6.2.4 Installation units type FVS-600/S (visible unit)

Step 5:

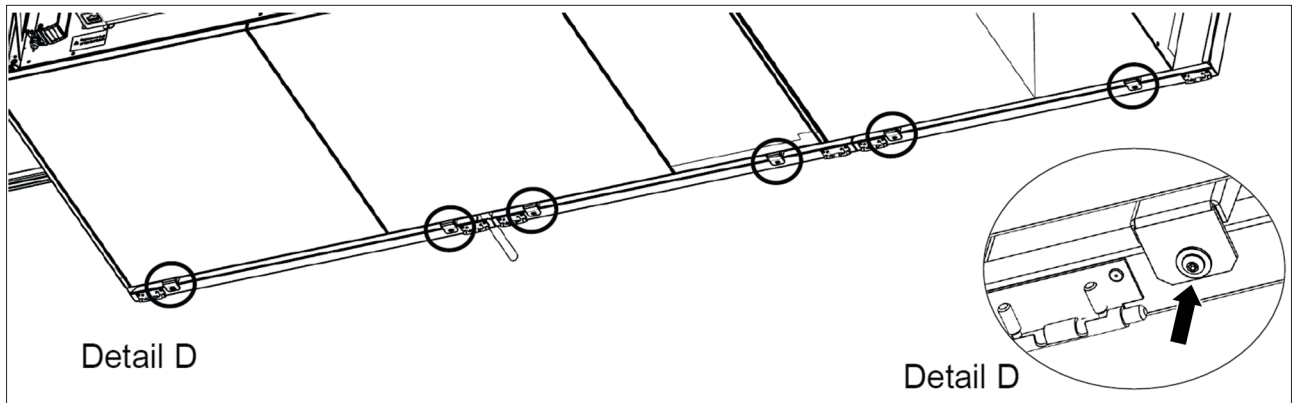

- Fasten covering plates (wall side) each with 2 pan-head screws M5x12 and 2 large washers M5 to the vertical lugs of the mounting rail.

Installation FVS-600/S

Continuation 6.2.4 Installation units type FVS-600/S (visible unit)

Step 6:

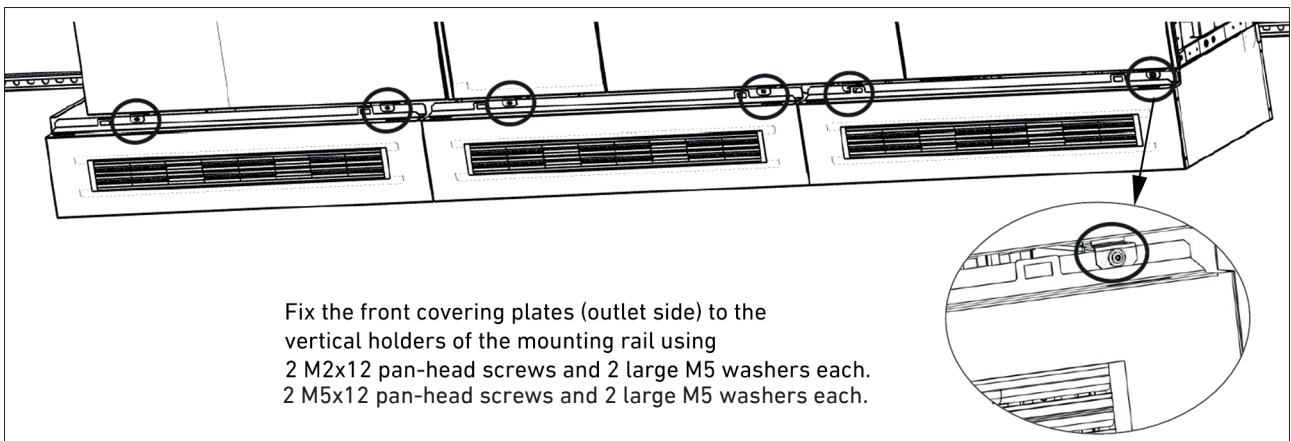
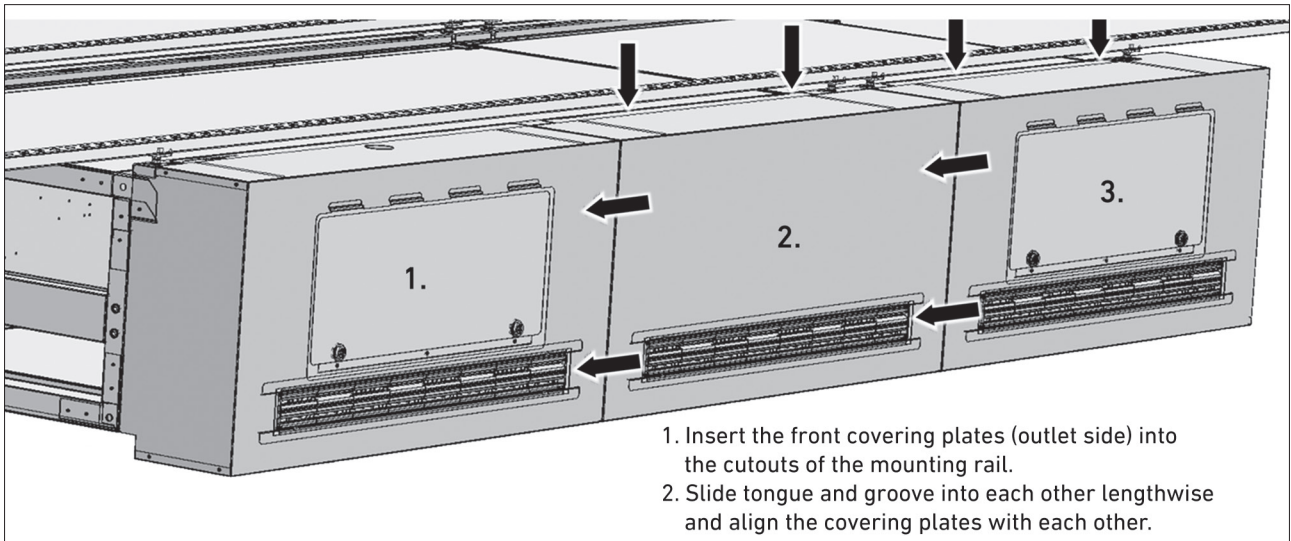
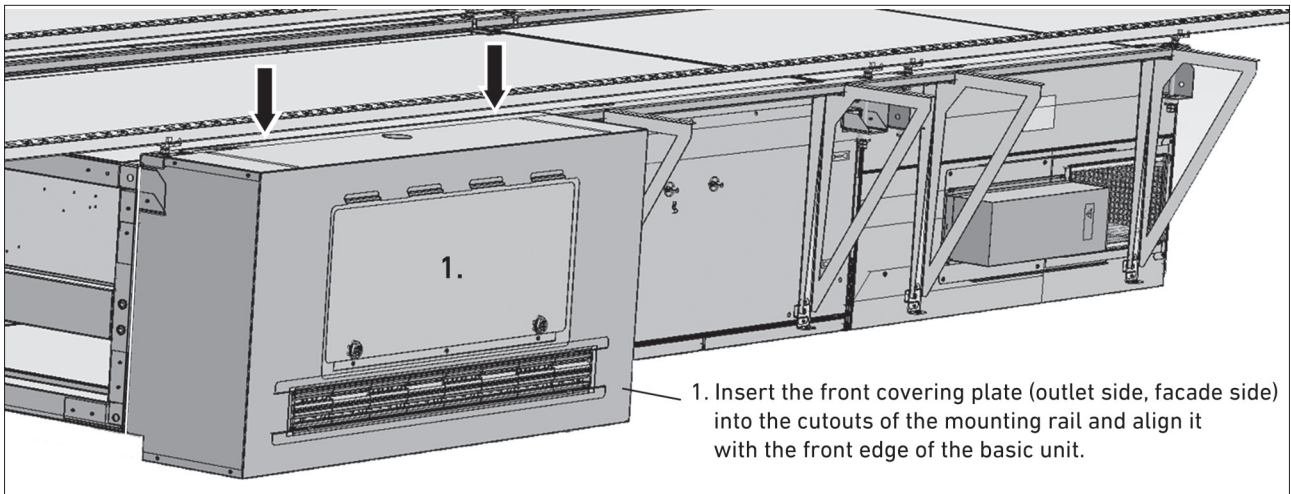

Installation FVS-600/S

Continuation 6.2.4 Installation units type FVS-600/S (visible unit)

Step 7:

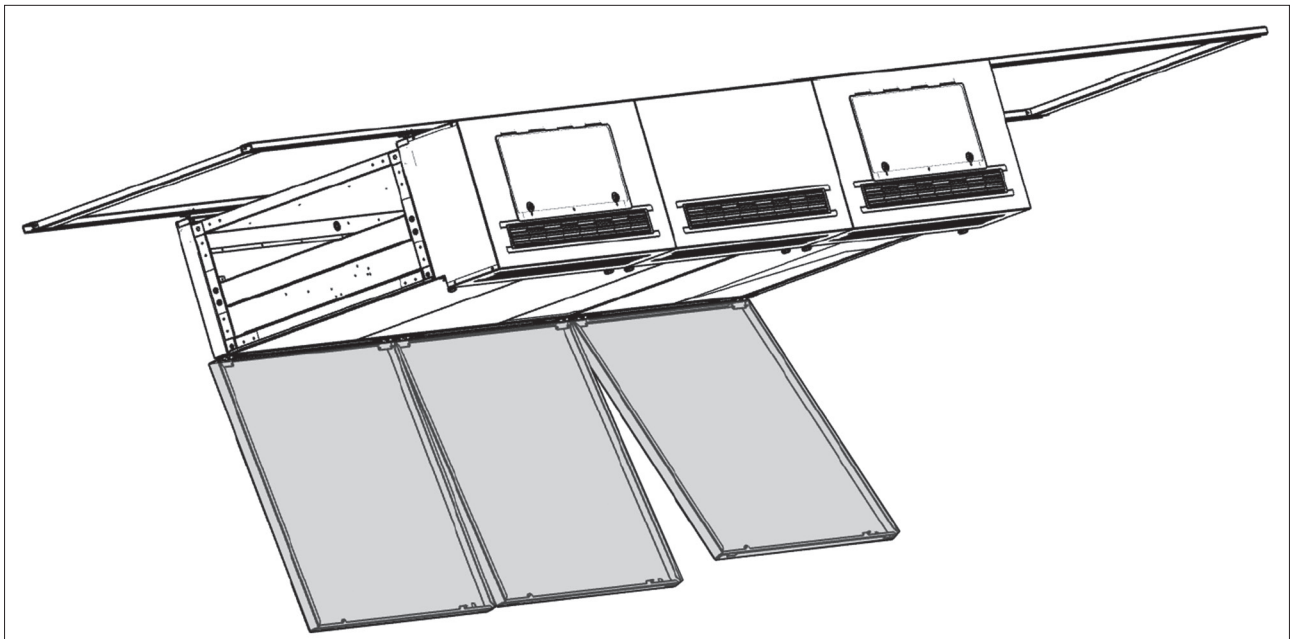

- Insert lower panels into the corresponding hinge halves of the rear panel (wall side).

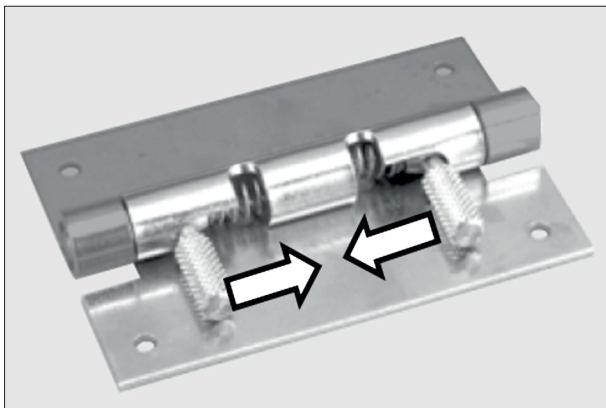

- To hook in the hinges, press the two spring-loaded levers together, see illustration. Align hinge parts and release lever. The hinge pins slide into the eyelets and the plates are hooked in movably.

These hinges allow the cover plates to be easily dismantled if necessary, e.g. for maintenance purposes.

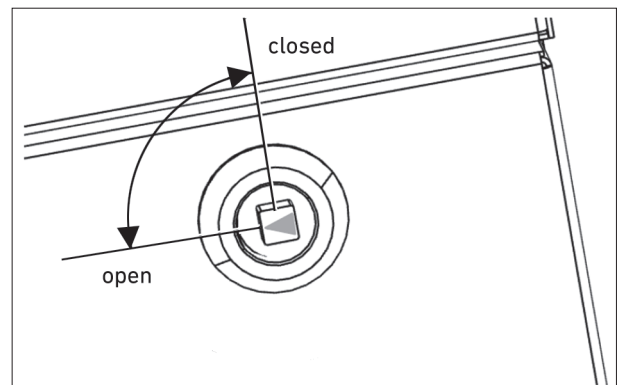

- Open the lock by turning it with the use of a square key. (arrow points in the direction of the latch).
- Fold the lower cover plates towards the unit and hold them in place.
- Close the locks by turning them ("closed" position).

Continuation 6.2.4 Installation units type FVS-600/S (visible unit)

Step 8:

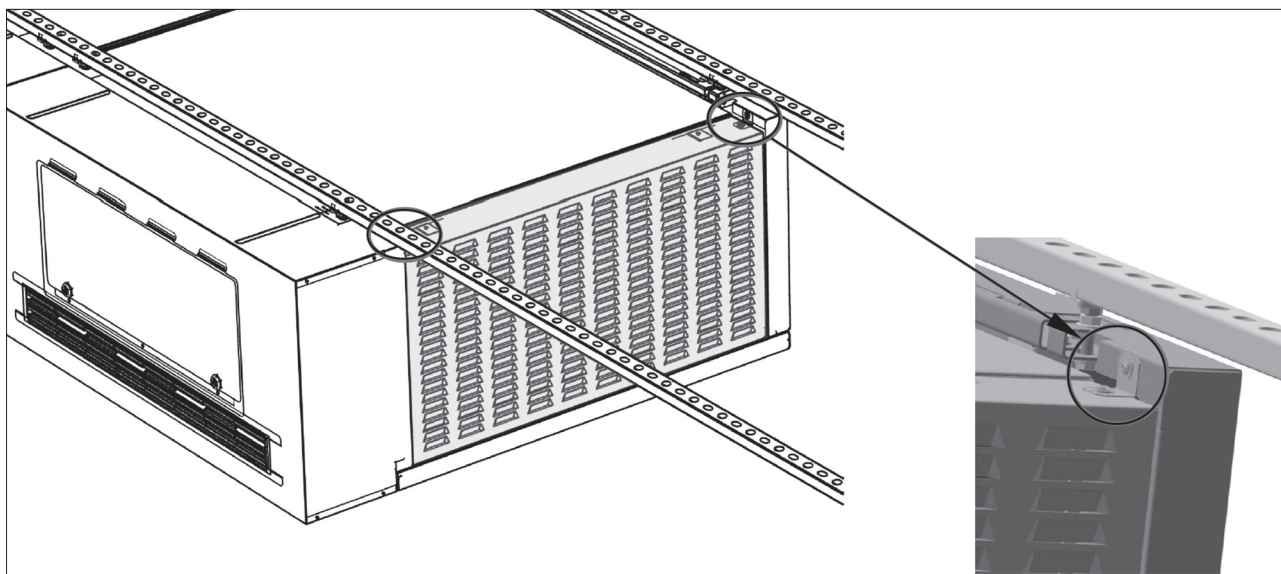

- Hang the exhaust air box and (if necessary) align it laterally using the retaining brackets and screws (M5x12).

Installation, connection to the facade

6.3 Connection to the facade

Install the standard version of ceiling mounted FVS-600 unit as ready-to-plug-in ventilation unit horizontally flush and up to the facade opening.

The weather protection grille supplied by the manufacturer is to be installed with its frame tight fitting in the facade cutout and should be fixed to the outer shell using an adhesive or screws.

The balancing line (optional, standard length 250 mm oder 500 mm) bridges a variety of thicknesses of outer wall and window constructions and isolates the FVS-600 unit from the facade. Lead this center-divided air conveyance line through the facade opening to the weather protection grille flange, then seal it using an adhesive sealant.

Suspension to the ceiling relieves the facade and ensures air and water tight connection to the weather protection grille. Open gaps in the facade cutout must be insulated from the inside and grouted to be permanently elastic. Larger gaps should be sheet covered for reasons of sound insulation.

In case adapter ducts are required on site (height difference between unit and facade opening, bypassing a ceiling girder, 90° floor plan deflection, etc.) observe the following rules:

- Use 1 mm sheet steel for air duct inside
- 40 mm mineral wool insulated case. Do not use Armaflex for acoustic reasons (closed pored cellular caoutchouc).
- Use 1 mm sheet steel for shell
- Clear cross-section outside air duct > 0.12 m²
- Clear cross-section exit air duct > 0.07 m²
- Airtight connection of adapter line (LTG supplied) to the weather protection grille
- Weather protection grille (LTG accessory)
- Free exit air discharge by 45° downwards, i.e. no obstruction caused by protruding facade elements, sun protection devices, etc.
- Inspection opening in LTG adapter duct recommended
- Exit air sound absorber possible (optional)
- Ensure slight slope towards facade (2...5 %)
- Use water-resistant seal with the facade



Execute the outside air and exit air lines air-tightly separated from each other (separate air lines).

Only use odour-neutral sealant.

Installation, connection to the facade

Continuation 6.3 Connection to the facade

Connection, general

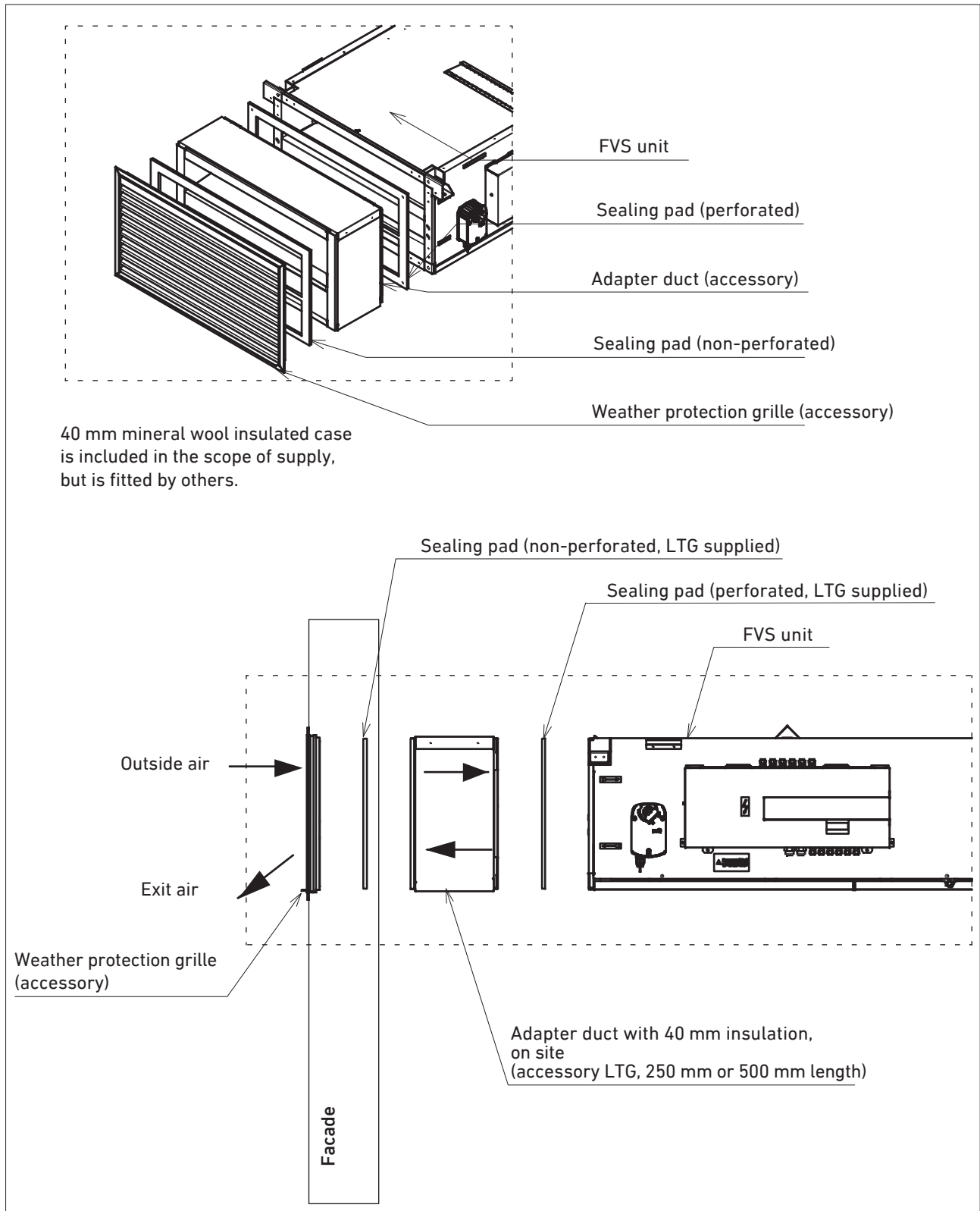

Installation, connection to the facade

Continuation 6.3 Connection to the facade

Dimensions type FVS-600/DI, integrated in ceiling panellings, air connections at facade side

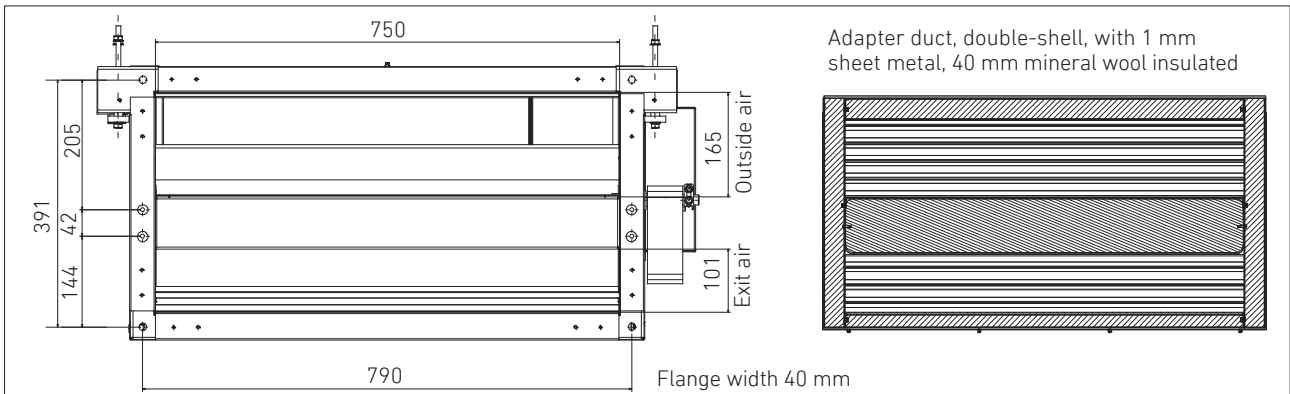

Dimensions type FVS-600/S, visible installation, air connections at facade side

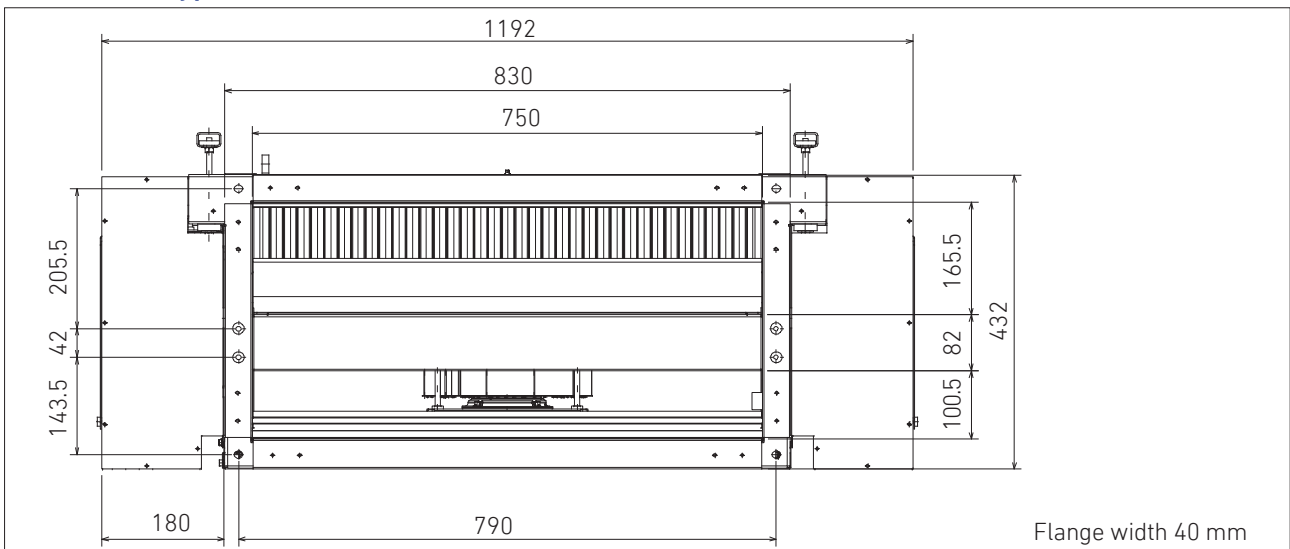

Right / left version

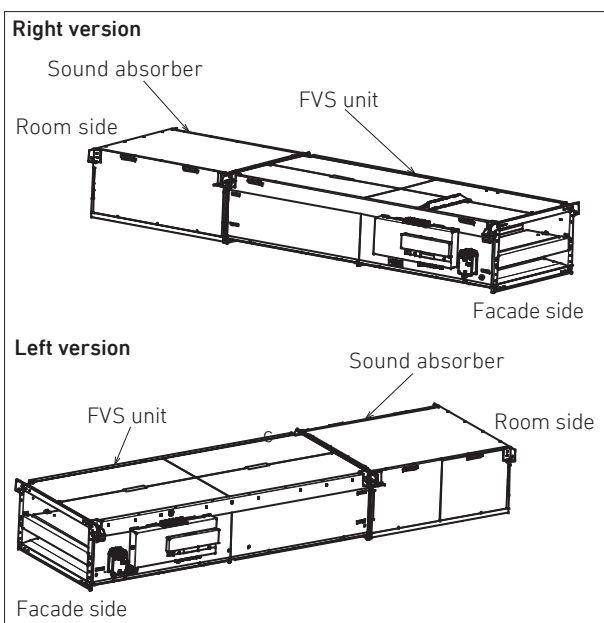

Installation, connection to the facade

Continuation 6.3 Connection to the facade

Type FVS-600/W, upright assembly

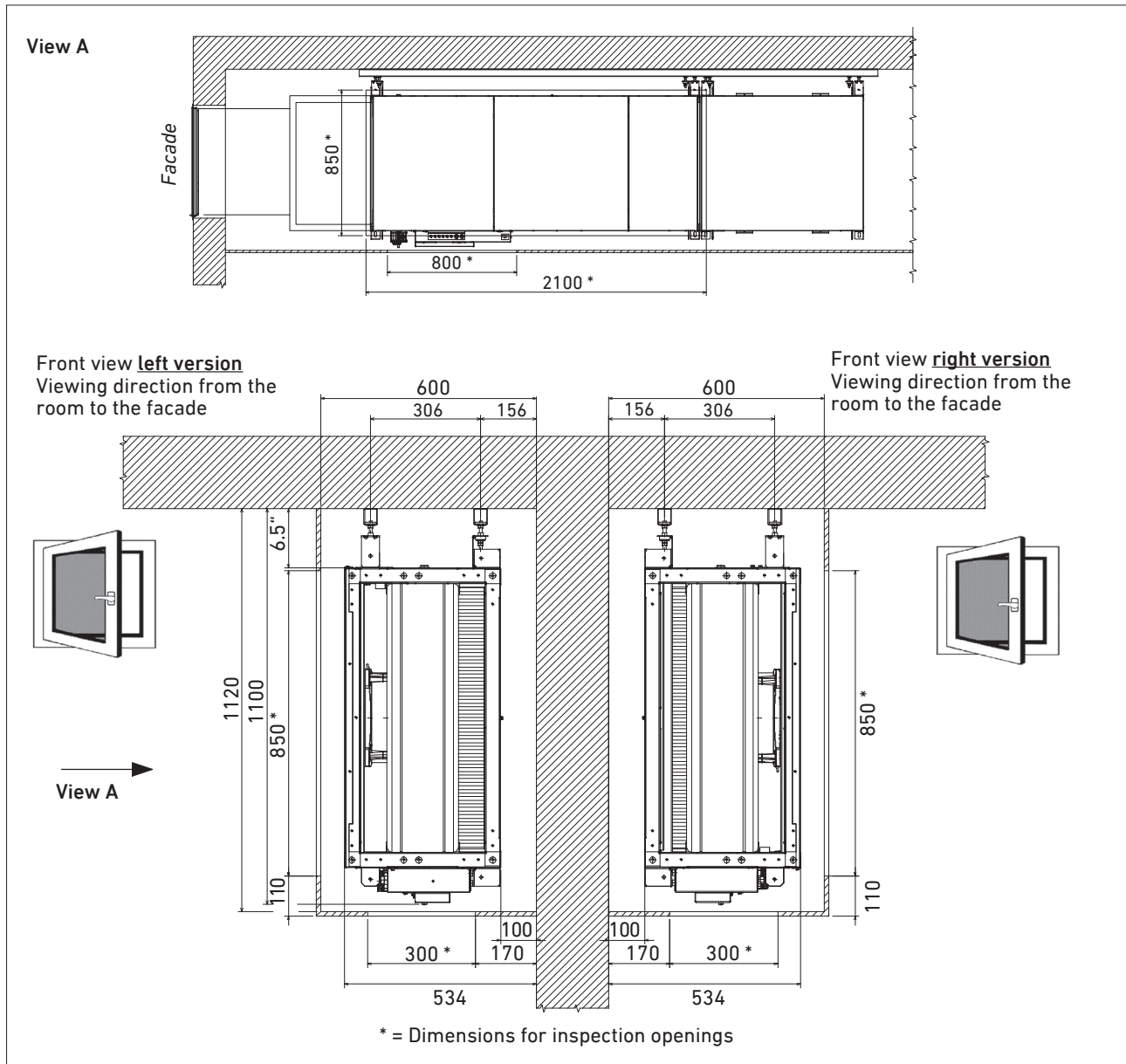

Installation, electrical connections

6.4 Electrical connections

Based on Machine Guidelines, the FVS-600 unit is considered an „incomplete machinery“ which requires the use of a maintenance switch allowing for complete disconnection from the main power supply before opening the unit or its terminal box. For the FVS-600 unit the power plug performs this function and has to be pulled whenever work on the unit is performed.



The unit must be connected to a fault-current circuit breaker (RCD). The supply lines, especially the earthing terminal (PE), must be connected by specialist staff according to the applicable statutory provisions. Before working on the unit, the mains plug must be pulled.

With a supply voltage of 230 V, the unit is provided with an integrated 4 A safety fuse.

Power consumption is 2.5 A max.

No more than 6 units must be connected in parallel to an RCD-switch. The measurement of the discharge current can have a discharge current of approximal 4.8 mA if devices are not connected to the power supply – EN 60355-1, chapter 16 – due to the control not being live (L-conductor is interrupted).

The HMI service tool can be used to read out and confirm error messages, read and adjust target values for temperatures and runtimes.

The remote switch FSG is not included in the delivery and will have to be provided on site. It offers the possibility to activate unit functions from a central location and will indicate malfunctions, if any. When connecting the remote switch FSG, the on-site electrical bridge between D1 and M must be removed.

It is possible to switch between:

- Ventilation mode „Com“, e.g. nominal flow rate 600 m³/h (switch M-D1)
- Ventilation mode „Eco“, reduced flow rate, e.g. 400 m³/h (switch M-D2)
- Nocturnal ventilation, Release of night ventilation with self-operated start-up and controlled deactivation (switch M-D3)
- Forced ventilation, Activation possible in the operating modes “Eco” and “Com”. The CO₂ level will be ignored. Ventilation will continue until “forced ventilation” is deactivated or the mode of operation changed.

Malfunctions are displayed as collective malfunctions and must be confirmed via the HMI unit:

Malfunctions are signaled in the event of sensor breakage or failure of the CO₂ sensor or automatic shutdown due to excessive room cooling.

Circuit boards see following pages.

Remote switch FSG (optional)

Dimensions 74 x 126 x 25 mm.

Minimum requirement: shielded 10-strand cable, cross-section at least 0.5 mm².

The following terminals must be connected to each other:

| FSG | | FVS-600 controller | |
|-----|----|--------------------|-----|
| 1 | M | 11 | Q24 |
| 2 | D3 | 12 | Q64 |
| 3 | D2 | 13 | Q54 |
| 4 | D1 | 14 | Q34 |
| 5 | D5 | 15 | Q44 |

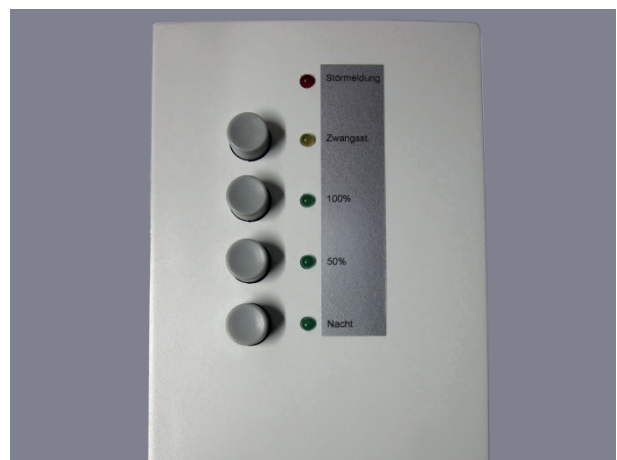

Remote switch FSG (optional)

CO₂ sensor (optional)

The following terminals must be connected to each other:

| FVS-600 board | | CO ₂ sensor (Thermokon) |
|---------------|------|------------------------------------|
| ⊥ | <==> | GND |
| S | <==> | AU1 (0...10 V DC) |
| + | <==> | UB+ (24 V DC) |



CO₂-sensor NOVOS 3 CO2 weiß (optional)

WRF06S room operating unit (optional, see page 40)

Continuation 6.4 Electrical connections

Circuit diagram 3: AHU module with filter monitoring, fire detector

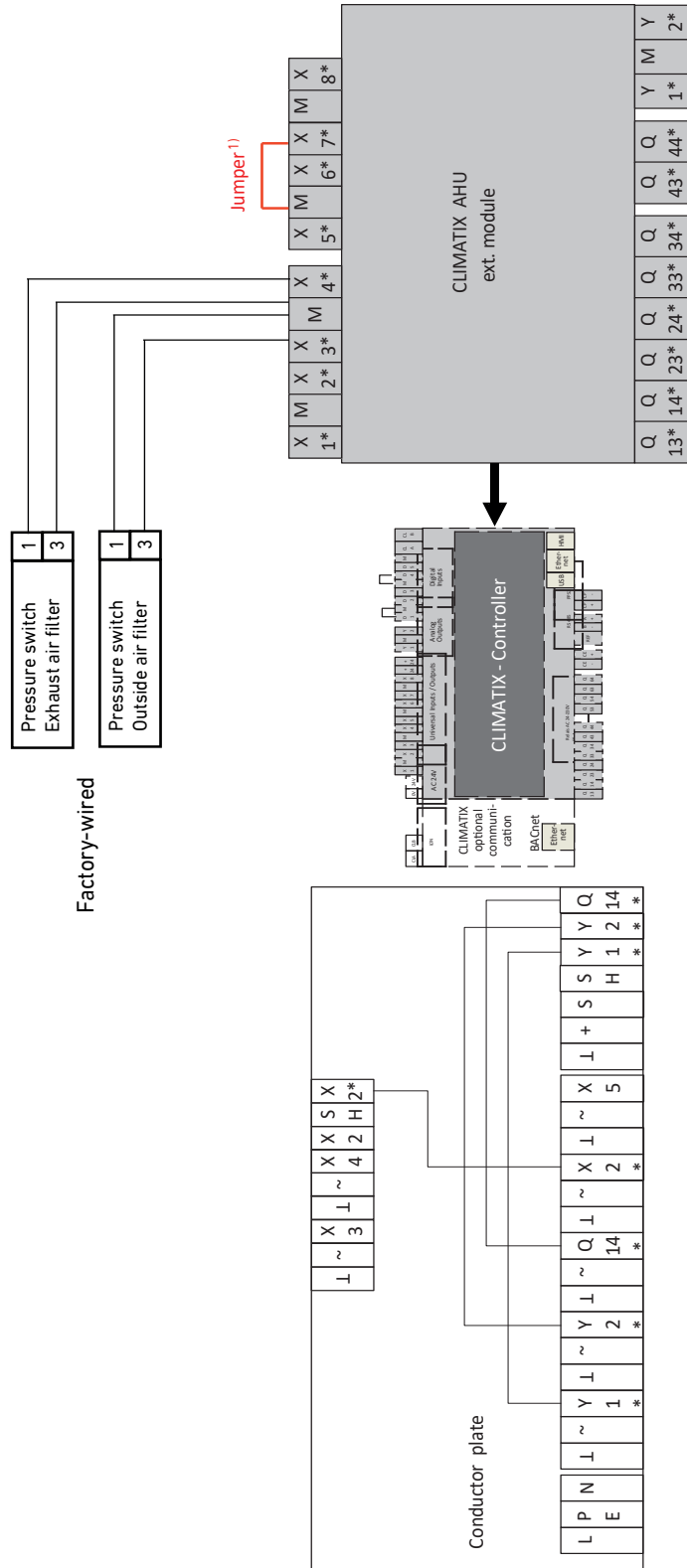

1) For connection of fire detector = remove jumper

 Dashed components are not in scope of delivery

* Terminal assignment AHU module
 This schematic diagram does not comply with actual dimensions!

Continuation 6.4 Electrical connections
 Room operating unit WRF06S (optional)

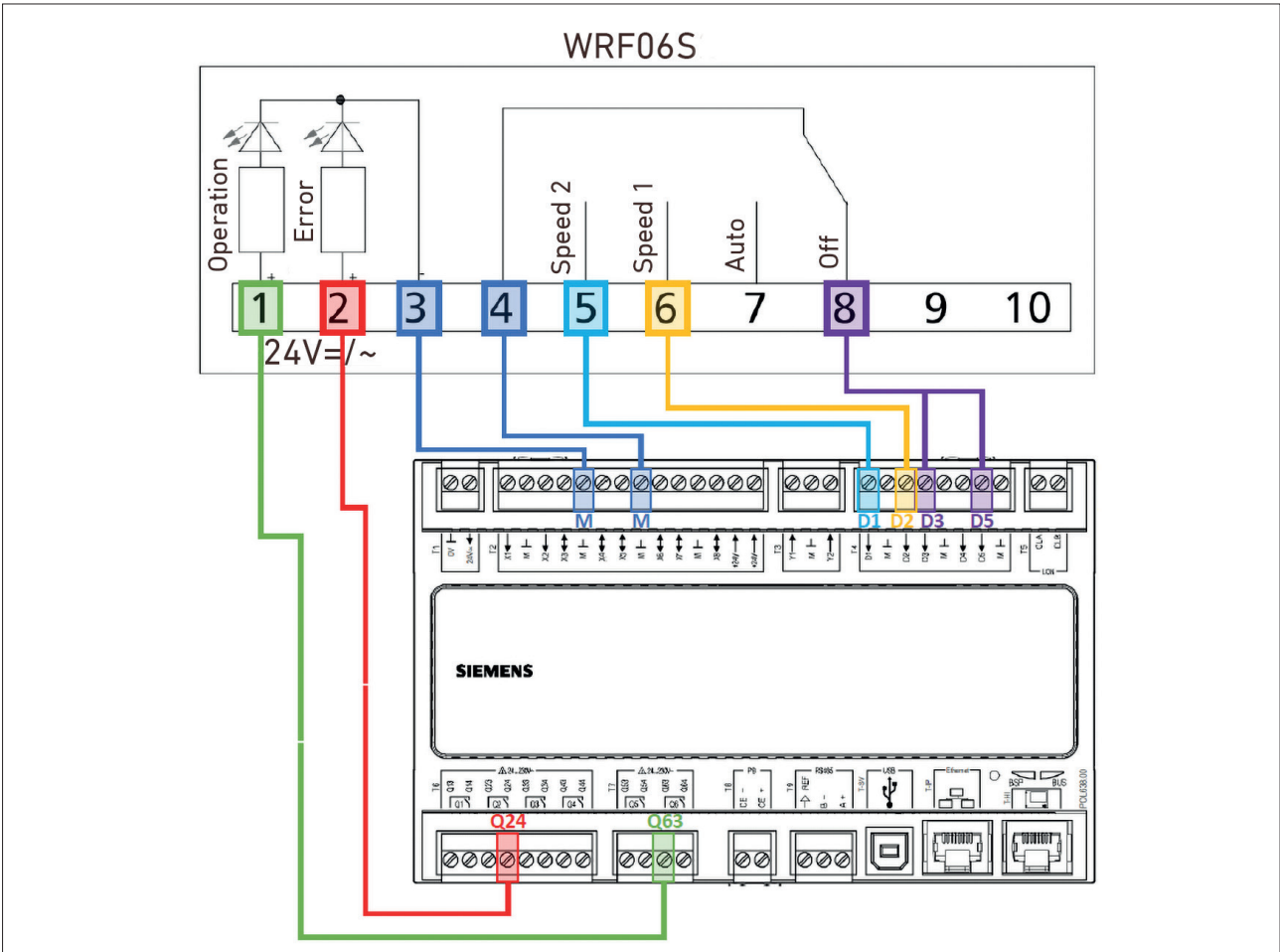

- Dimensions: 81 x 81 x 38 mm (flush-mounted)
- Operating modes: Off, Auto, I „ECO“ und II „COM“
- LED display for operation and error

All operating modes run after selection for the programmed runtime (programmable using the HMI, 0 - 300 min.)

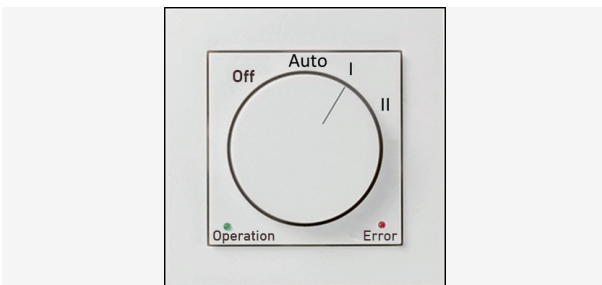

After the running time has elapsed, the appliance switches to the operating mode according to the timer programme or GLT.

To reactivate the operating mode, briefly set the switch to „Auto“ and then select the desired operating mode.

If a CO₂ sensor is connected to the FVS, the volume flow in operating modes I and II is regulated according to CO₂ as required up to the set air volume.

Room operating unit WRF06S

| Operating mode | Description |
|----------------|------------------------------------------|
| Off | The unit is switched off |
| Auto | The unit runs according to timer program |
| I | Level 1 (low air volume) |
| II | Level 2 (high air volume) |

Installation, electrical connections

Continuation 6.4 Electrical connections

Terminal assignment

| IO | Function | IO type | Terminal | Description |
|---------------------------------|---------------------------------------|-------------------------|--------------|------------------------------------|
| Relay outputs | | | | |
| Q1 | Board Power | Digital | T6 (Q13,Q14) | Energy saving mode (factory wired) |
| Q2 | Collective fault | Digital | T6 (Q23,Q24) | When using a remote switchgear FSG |
| Q3 | Display „Comfort“ active | Digital | T6 (Q33,Q34) | |
| Q4 | Display „Forced“ active | Digital | T6 (Q43,Q44) | |
| Q5 | Display „Reduced“ active | Digital | T7 (Q53,Q54) | |
| Q6 | Disp. „Night ventilation“ act. | Digital | T7 (Q63,Q64) | |
| Analogue inputs | | | | |
| X1 | Supply air temperature | Passive (Ni 1000) | T2 (X1,M) | |
| X2 | Exhaust air temperature | Passive (Ni 1000) | T2 (X2,M) | Factory wired |
| Binary inputs | | | | |
| D1 | Comfort | Digital | T4 (D1,M) | Factory bridge |
| D2 | Reduced | Digital | T4 (D2,M) | |
| D3 | Night ventilation on | Digital | T4 (D3,M) | |
| D4 | Window contact | Digital | T4 (D4,M) | Factory bridge |
| D5 | Forced control | Digital | T4 (D5,M) | |
| Universal inputs/outputs | | | | |
| Y1 | Supply air fan setpoint | Analogue (0...10 V) Out | T3 (Y1,M) | Factory wired |
| Y2 | Exhaust air fan setpoint | Analogue (0...10 V) Out | T3 (Y2,M) | Factory wired |
| X3 | Outdoor air damper | Analogue (0...10 V) Out | T2 (X3,M) | Factory wired |
| X4 | Bypass | Analogue (0...10 V) Out | T2 (X4,M) | Factory wired |
| X5 | Cooling valve | Digital | T2 (X5,M) | |
| X6 | Outdoor temperature | Passive (Ni 1000) | T2 (X6,M) | |
| X7 | CO ₂ sensor | Analogue (0...10 V) | T2 (X7,M) | |
| X8 | Exhaust air temperature | Passive (Ni 1000) | T2 (X8,M) | Switchable to active 0...10 V |
| POL955, Relay outputs | | | | |
| Q1 | — | Digital | T3 (Q13,Q14) | |
| Q2 | Shutdown CO ₂ sensor | Digital | T3 (Q34,Q24) | Factory wired |
| Q3 | | Digital | T3 (Q33,Q34) | |
| Q4 | | Digital | T3 (Q43,Q44) | |
| Analogue outputs | | | | |
| Y1 | | Analogue (0...10 V) | T5 (Y1,M) | |
| Y2 | | Analogue (0...10 V) | T5 (Y2,M) | |
| Universal inputs/outputs | | | | |
| X1 | Digestorium 1 | Digital | T1 (X1,M) | |
| X2 | Re-heater | Analogue (0...10 V) Out | T1 (X2,M) | |
| X3 | Pressure load cell supply air filter | Digital | T1 (X3,M) | |
| X4 | Pressure load cell exhaust air filter | Digital | T1 (X4,M) | |
| X5 | | | T3 (X53,X54) | |
| X6 | | | T3 (X63,X64) | |
| X7 | Fire | Digital | T1 (X7,M) | Factory bridge |
| X8 | | | T3 (X83,X84) | Factory bridge |

Installation, commissioning

6.4.1 External communication via network (optional)

The following communication types are available:

- BACnet
- LON
- MODBus-RTU (slave)
- KNX S-Mode

For communication of the FVS-600 unit with the building control technology (GLT) via LON or BACnet, the corresponding communication module must be connected on site in the control box of the device at the controller if it is not integrated in the controller. It is enclosed with the mounting accessories and marked with "electrical accessories / Elektrozubehör".

A module is required for the communication types LON and BACnet. The connections for the communication types KNX S-Mode and MODBus-RTU are already integrated into the controller.

The module is connected to the left of the controller with the enclosed bridge. It is pushed onto the present tophat rail and then pushed to the right onto the controller and connected to the controller with the bridge (connector).

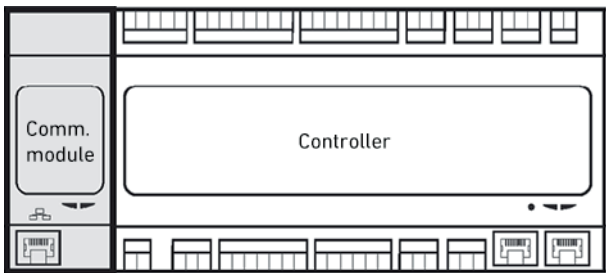

The communication module is recognised independently by the controller.

Our LON or BACnet lists list all parameters/values that can be read out or changed. If you have not received this list in advance of the planning, you can request it from LTG Aktiengesellschaft.

6.5 Inspection after installation

| | |
|-----------------------------------------------------------------------------------|-------------------------------------------------------------------------------------------|
|  | It must be checked that the device is connected to a fault-current circuit breaker (RCD). |
|-----------------------------------------------------------------------------------|-------------------------------------------------------------------------------------------|

Mechanical inspection

After completion of the installation, the device must be inspected for mechanical damage. Packaging residue or dirt at and in the device must be removed.

The following must be inspected:

- the unit suspensions incl. the mounting rails for firm heavy-load anchors, screw connections, for completeness
- the sound and vibration insulation against the building (ceiling, facade) via elastic insulation discs and the enclosed neoprene flange seals and screw sleeves
- the tightness of the flange connections, especially between the outside and exit air lines
- the elastically tight connection of the air lines at the weather protection grid
- the continuous insulation shell between the unit and the facade (sound and heat protection)
- free outflow of the exit air in front of the facade
- free intake of outside air from in front of the facade
- the horizontal and accurate alignment of all unit components
- the movability of the combined outside air/exit air flap visible by rotating movements of the motor terminal block and limitation by stop

Media supply control

The following must be inspected:

- the electrical connections for professional design and compliance with the relevant provisions
- voltage and mains frequency. They must match the information at the rating plate of the terminal box. No control units with wrong voltage or frequency must be operated, since this may cause destruction of the devices and danger to persons.

Control of the regulation

The following must be inspected:

- connection and position of the temperature sensor for supply air (at the lower splitter gap)
- connection and position of the temperature sensor for exhaust air (in the area of the exhaust air diffuser)
- connections and position of the CO₂ sensor (in the area of the exhaust air diffuser)
- external connections to release (Eco, Com, nocturnal ventilation)
- control box for type FVS-600/S lateral in the outlet boxes

Commissioning, alarm, malfunctions

7. Commissioning

Start-up must only take place after complete installation and after all inspections. Direct switching on and off of the device via the external switches (Eco, Com, nocturnal ventilation) is only possible when no CO₂ sensor has been connected and the parameters have been set via the service tool HMI. The device is switched by the output signal of the air quality sensor only in the small and large ventilation stages. The exhaust and supply air temperature sensors must be connected correctly as well with the air quality sensor.

After external release (Eco or Com), the FVS-600 unit will only switch on if

- the CO₂ concentration in the room exceeds the threshold (target values CO₂ Com or Eco SW-on = 1000 ppm)

Activation and deactivation may be reviewed in a well-ventilated room by breathing onto the CO₂ sensor.

7.1 Function test

If all connections are established according to the circuit diagram (see chapter 6.4), the function of the unit can be reviewed as follows:

1. Push the button "Eco" or "Com" on the enclosed remote control unit. Now the respective green LED above it must light up.

If no remote control unit (external release) is connected, bridging is possible with a cable either at the controller from M to D1 (Com) or to D2 (Eco).

2. Breathe into the connected CO₂ sensor.
3. The unit must start up after a brief delay.

Optional: Function test with HMI service tool

A detailed function description for the HMI service tool is available as an additional document. Find a short description below.

1. Connect the HMI service tool (optionally available from LTG Aktiengesellschaft) to the RJ45 socket at the controller.

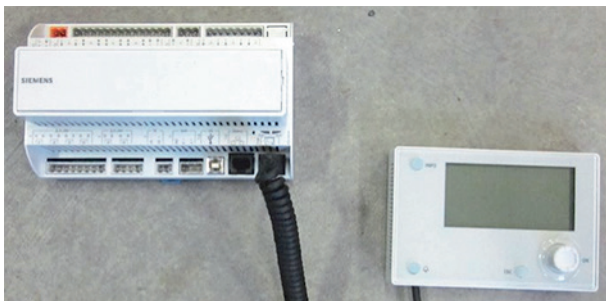

2. Display HMI

When the sensor is connected, the actual values are displayed for the following sensors:

| | |
|---------------------------------------------|--------------------|
| AU –temp. (if present) | (AU = outside air) |
| ZL –temp. | (ZL = supply air) |
| AB –temp. | (AB = exhaust air) |
| FO –temp. | (FO = exit air) |
| CO ₂ -concentration (if present) | |

7.2 Alarm, malfunctions

If the unit has not started up after 30 seconds, or if the red LED is lit at the remote control unit, an alarm or fault is pending. Connect the HMI service tool (optionally available from LTG Aktiengesellschaft) to the RJ45 socket at the controller.

Check the following values:

1. Operating mode --> possible display:

Fault, Com, Eco, night ventilation, forced ventilation.

2. For operating mode "Eco" or "Com", the following values must be reviewed:

Supply air, exhaust air, exit air temperature in °C (ZL-temp., AB-temp., FO-temp.)
CO₂-value display in ppm

If no values are displayed here, the corresponding sensor is not properly connected or defective.

If an alarm or fault is pending, the fault must be removed and should then be confirmed with the HMI service tool.

Commissioning, alarm, malfunctions

Continuation 7.2 Alarm, malfunctions

Triggering a fault message and switching off the device

| Indication HMI | HMI red light | Tableau LED light | Measured value | | Parameters HMI | Standard value | Description | Action | Indication alarm history | |
|------------------------|---------------|-------------------|------------------------------------------------|---|--------------------|----------------|-------------------------------------------|--------------------------|----------------------------------------------------------|----------------------|
| fault: AB temp. | X | X | Exhaust air temperature | = | | | Sensor out of order or cable interruption | Repair and confirm fault | no sensor | |
| fault: ZL temp. | X | X | Supply air temperature | = | | | | | no sensor | |
| fault: FO temp. | X | X | Exit air temperature | = | | | | | no sensor | |
| fault: none | X | - | Outside air temp. (if available) | = | | | | | no sensor | |
| fault: CO ₂ | X | X | CO ₂ concentration | = | | | | | underRange oder overRange | |
| fault: none | X | - | Actual room temperature (if available) | = | | | | | room control unit out of order or cable interruption (*) | room temp. overRange |
| fault: none | X | - | Room temperature setpoint shift (if available) | = | | | | | room control unit out of order or cable interruption | setpoint shift |
| fault: AB temp. | X | X | Exhaust air temperature | < | AB threshold value | +15 °C | Cooling protection | AB threshold value fault | | |

(*) unit does not switch off

Legend: ZL = supply air, AB = exhaust air, FO = exit air, AU = outside air

The unit does not start up

In ECO-mode or COM-mode:

Exhaust air temp. (= room temp.)

< supply air target
(factory setting: 17 °C)

CO₂ value

< 1000 ppm

In nocturnal ventilation mode:

Temp. exhaust air ACTUAL < 19 °C

Temp. difference supply air/
exhaust air ACTUAL < 2 K (Kelvin)

Temp. supply air ACTUAL < 5 °C

Alarm/fault confirmation

- The alarm and history lists can contain up to 50 entries each.
- Each alarm is reported with plain text, report class, alarm group, date and time.
- Every newly arriving alarm generates a line both in the alarm list and in the history list.
- An active alarm is pending: The alarm LED on the external HMI flashes.
- A confirmed, but still active alarm is pending: The alarm LED on the external HMI remains lit.
- Reset alarms:
 - a. Alarm list: Line will be deleted
 - b. History list: Presentation as going alarm.

Information on the active alarms in the "Alarm list":

Line 1:

- Display of alarms that are not confirmed, e.g. Acknowledge Passive x.
Pushing the setting button and selection of "Active" resets or confirms all unconfirmed alarms even if the fault has been removed but saved in the alarm history.

Further lines:

- Pushing the setting button shows detailed information on this alarm.
- Pushing the alarm button will display the settings list.

Information on the active und passive alarms in the "Alarm history":

Line 1:

- Display of all acknowledged and unacknowledged alarms.

Further lines:

- +Name of the alarm: Condition. Example:
+AB limit fault: Alarm (income alarm)
-AB limit fault: OK (gone alarm)
- Pushing the setting button shows detailed information on this alarm.
- Pushing the alarm button will display the settings list.

Operation, maintenance, repair

8. Operation, maintenance, repair



Maintenance and servicing work must only be performed by specialist staff.

When working at the unit, the worksite must be secured against unauthorised access. Persons must not be directly under the device.

All work must only be performed with suitable tools and suitable protection clothing and must only be performed by instructed persons.



Before starting the maintenance, pull the mains plug and disconnect the device from the power supply on all connections; secure it against reactivation.

The connections to the condensate grid must be disconnected; the siphon must be emptied.

The unit must be cleaned and serviced in the due time and professionally according to the applicable hygiene provisions (VDI 6022). For maintenance of the unit, clean the condensate tray, the fans, the air flaps, the air-circulated inner walls and the heat recuperator, and exchange the two air filters.

8.1 Opening the unit

For opening, turn out the screw on the right of the middle lid, turn the closures outwards and slowly lower the lid. Then completely disconnect the lid and take it off downwards; if required, remove the holding lines.

Disassembly of condensate tray

The condensate tray is integrated in the inner middle lid. It can be folded down and pulled sideways out of the suspension by releasing three screws on the left.

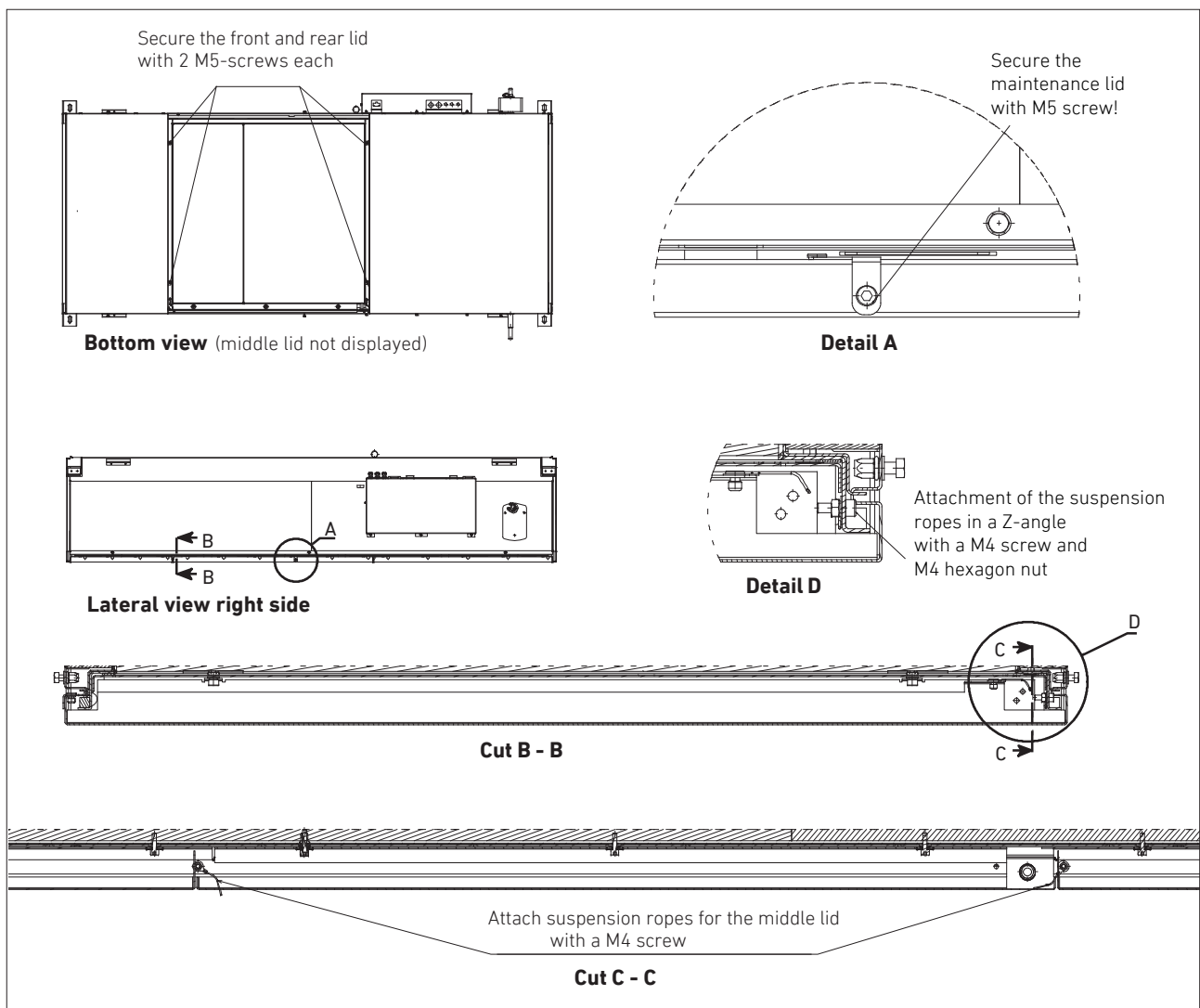

Operation, maintenance, repair

8.2 Filter change

The pressure loss of both air filters is monitored by means of differential pressure switches and displayed as a warning message when exceeded.

The fresh air filter must be changed annually for hygienic reasons (VDI 6022).

The filters are only accessible after disassembly of the condensate tray! (see chapter 8.1)

Unlock the filter lid by turning the closures downwards, fold them down and pull them out to the side.

Pull out the used filter and replace it with a new filter with the specified filter class.



The supply air filter is located on the facade side and is marked ePM1 80% (corresponds to F8/F9).

The exhaust air filter has class ePM10 50% (corresponds to M5) and is located on the room side.

When replacing the filters, observe the flow direction indicated on the side of the filter. The direction of the arrow on the filters must correspond to that under the filter cover.

Before installation, clean the sealing surfaces and check the seals and replace them if necessary.

8.3 Inspect heat recuperator unit, clean, remove if necessary

The heat recuperator unit (HRU) is protected from dirt by air filters. Dust deposits in the air entry cross-sections can be removed with a soft vacuum cleaner brush.

Only when clear contamination is visible inside will the heat recuperator unit have to be moved. The plate package can be cleaned wet with high-pressure cleaners. It is important that enough distance is left between the high-pressure nozzle and the heat transfer medium in order to avoid mechanical damage!



The weight of the heat recuperator unit is approx. 20 kg!

The heat exchanger must be removed by two persons using suitable aids to secure a stable stance and protect against falling parts.

After releasing the attachment screw, there is a danger of the heat recuperator falling off!

The heat recuperator unit is only accessible after disassembling the condensate tray.

Fold down the heat recovery unit by loosening the fastening screws on the corresponding side, then unhook it on the opposite side by pushing up.

When working at the heat recuperator, observe that the lamellas of the plate heat exchanger are not damaged. Commercial suction lifters facilitate handling.

Maintenance, cleaning

Continuation 8.3 Inspect heat recovery unit, clean, remove if necessary

Step 1: Open cover

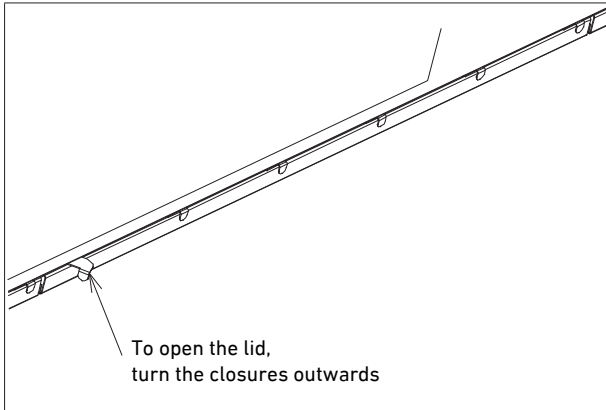

Step 3: Unscrew condensate tray

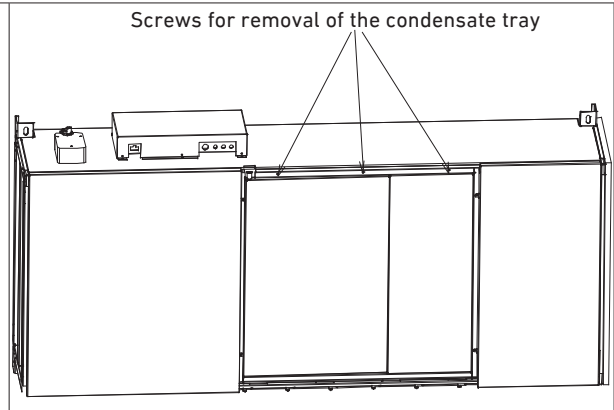

Step 2: Fold the lid down

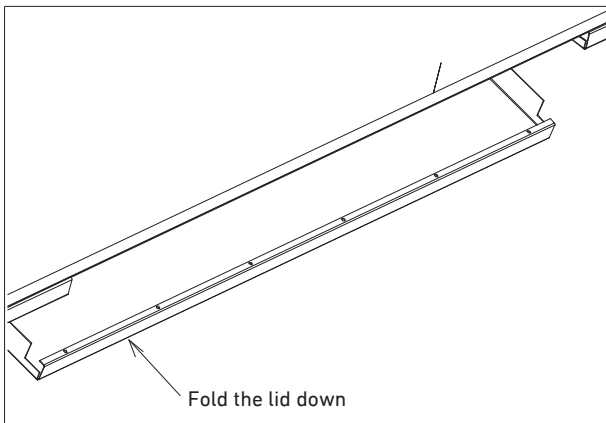

Step 4: Drop off condensate tray

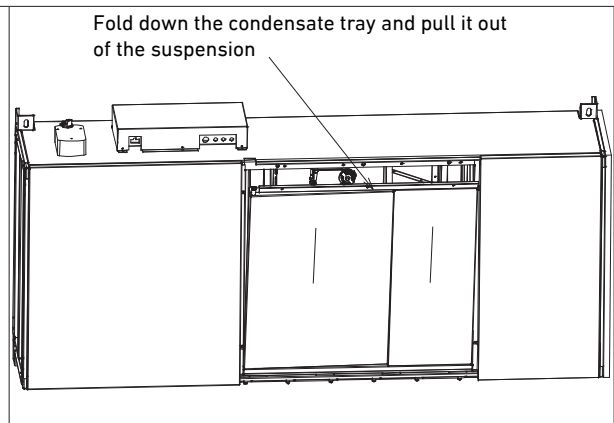

Step 5: Unscrew filter cover and heat recuperator

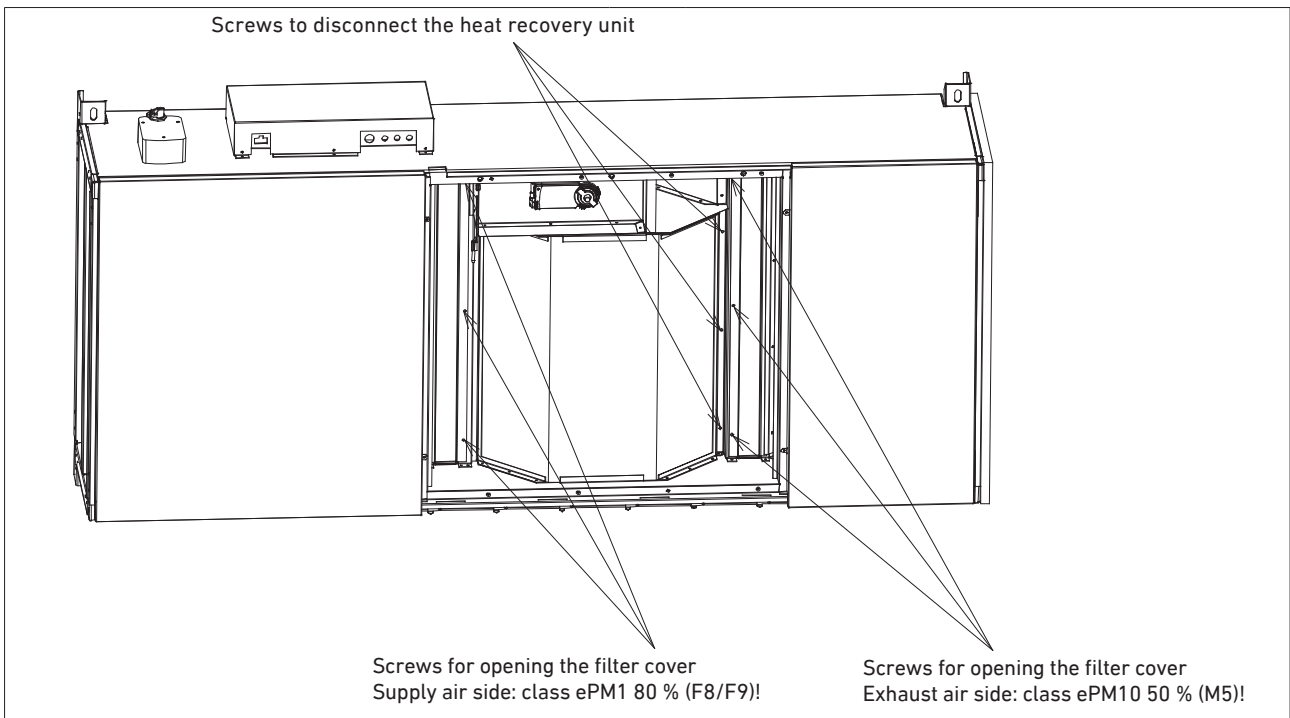

Maintenance, cleaning

Continuation 8.3 Inspect heat recovery unit, clean, remove if necessary

Step 6: Unhinge heat recuperator

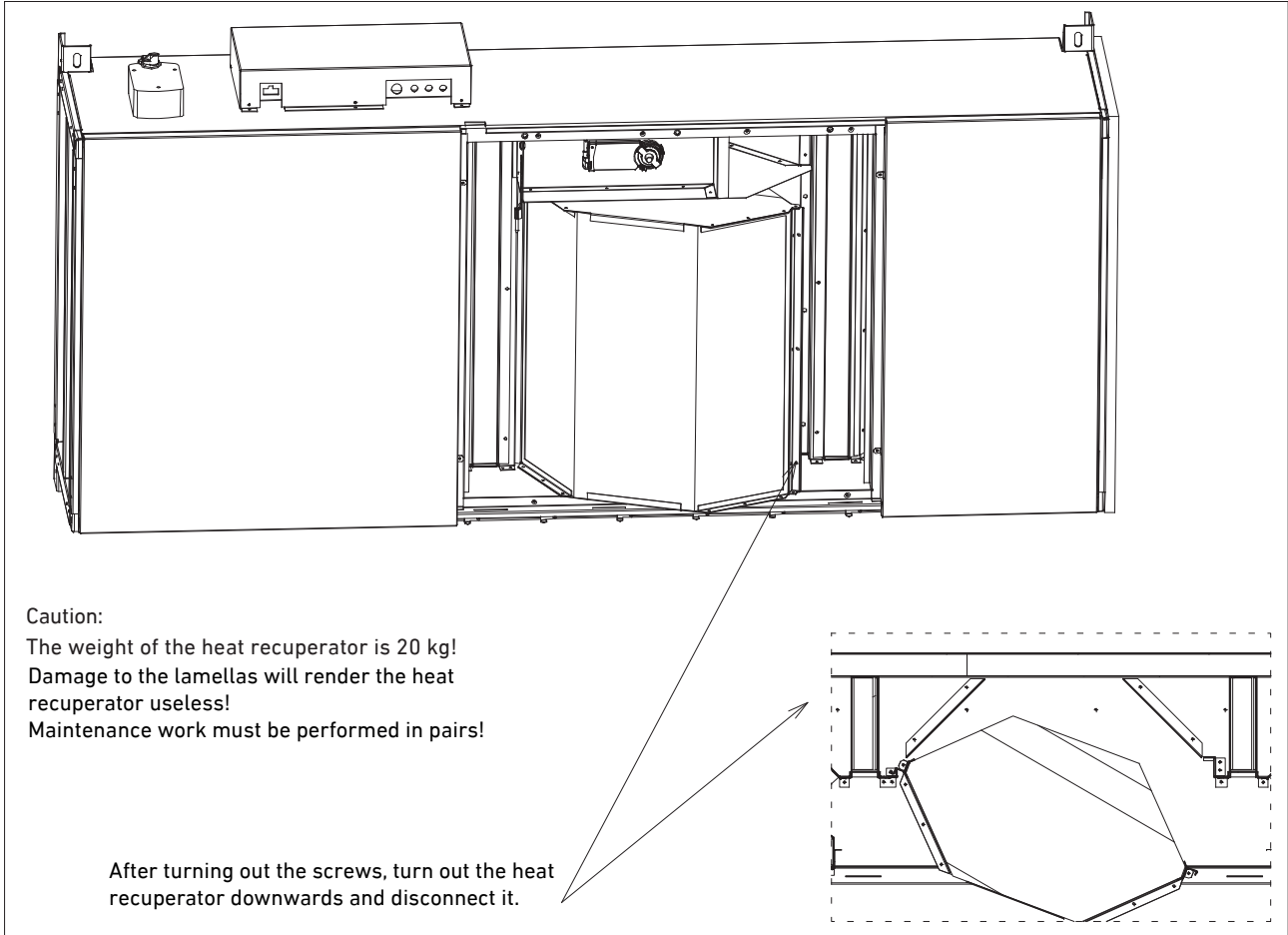

Maintenance, repair

8.4 Cleaning the surfaces and fans

All air-contacted surfaces and air flaps are made of galvanised sheet steel and are easy to clean moist or dry.

The fans are accessible after removing the outer lids and can be cleaned with a cloth or brush.

8.5 Intervals for hygiene inspection and cleaning

A good hygienic condition must be complied with in the FVS-600 ventilation unit if the intervals specified according to the intervals specified in VDI 6022 (hygiene requirements to comfort air systems and units, April 2006) for hygiene control:

At the latest after 12 months:

- Replace outside air filter
- Inspect exhaust filter, replace if badly contaminated; replacement is recommended after 12 months if the device has not run more than 1000 h, otherwise, replacement is recommended after no more than 24 months.
- All parts through which secondary air flows (exhaust air from the room) must be inspected for contamination and cleaned
- Clean heat exchanger or heat recuperator (if possible in spring, after 6 months of condensing operation).
- Clean condensate tray (if possible in spring, after 6 months of condensing operation)
- Clean fans, check for function

8.6 Repair, replacing a fan



The discharge time of the electrical capacitors in the motor is five minutes!

After pulling the mains plug, the motor may still be live! After disconnection from the voltage supply, wait for the discharge time (at least 5 minutes), before starting work on the fan.

Work must only be performed by an electrician!

Before replacing a fan, check that the EC motor of the fan is supplied with mains voltage (230 V AC) and control voltage (2...10 V DC).

A detailed circuit diagram must be requested from the manufacturer!



For reasons of safety, the fan must be disconnected after switching off the mains supply to prevent accidental start-up!

The motor plate can be removed after loosening the screws, including the mufflers at the motor and impeller. The spacer bolts must not be released for this.

When installing, observe that the impeller cover disc does not scrape on the inflow nozzle. At irregular run: Clean impeller and replace it if necessary or have the manufacturer balance it.

8.7 Repair, replacement of the spring return drive

If the combined outside/secondary air flap does not lock properly or seals in the 100 % open position, check the clamp screw connection. The flap position is evident by the groove of the axis from the outside.

The drive for the outside/secondary air flap is on the housing next to the electrical box.

Before disassembling the actuator, open the electrical box and remove the actuator cable from the terminals (see circuit diagram).

To replace the actuator, release the nuts at the terminal screw connection and remove the twist protection with the two tapping screws. Pull the actuator from the axis.

When installing the actuator, observe the flap position and set the drive to the right or left-hand stop (rotation 90 ° to the left or right).

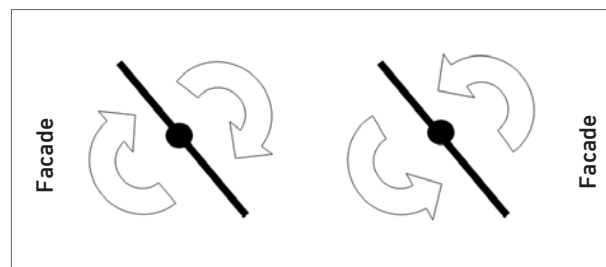

*Left-hand stop
(left unit)*

*Right-hand stop
(right unit)*

The flap must be in the closed position with the actuator off (vertical position) and must be perfectly tight (flush with the upper and lower seal).

During installation, open the front maintenance cover and put the flap into the correct position.

When tightening the drive on the axis, press the flap against the seal.

Maintenance, battery replacement

8.8 Repair, exchange heat recuperator bypass flap

The drive for the bypass flap is inside the device above the condensate tray.

To exchange the drive, the middle cover must be opened (see chapter 7.1).

Before replacing the actuator of the bypass flap, remove the cable at the side wall of the housing (see circuit diagram).

To disassemble the actuator, remove the magnet (orange) from the calliper and release the clamping screw. Pull the drive downwards out of the attachment clip.

Before installing the new actuator, set the left stop to approx. -15° and the right stop to 60° (motor turns to the right).

The flap is in the closed position with the unit switched off!

When installing the new drive, close the flap against the housing to the stop and tighten the clamping screw.

8.9 Replace backup battery (button cell) for Climatix timer

The timer integrated in the Climatix controller is necessary for time-dependent functions such as timer schedules, alarm timestamps or data times.

The power reserve of the timer is

- 3 days without backup battery
- 4 years with backup battery

Required spare part: Button cell lithium battery BR2032



Observe rules for handling button cells:

- Avoid electrostatic discharge during insertion (ESD protection by touching an earth point)
- Prevent contact with water
- Only use undamaged and clean button cells
- Electrolyte leaking from damaged button cells is caustic and corrosive! Do not touch with unprotected hands! In case of eye contact, rinse with plenty of water and seek medical attention!
- Store and dispose of button cells in accordance with local regulations

De-energise the controller to replace the button cell. To do this, disconnect the FVS device from the power supply on all sides.

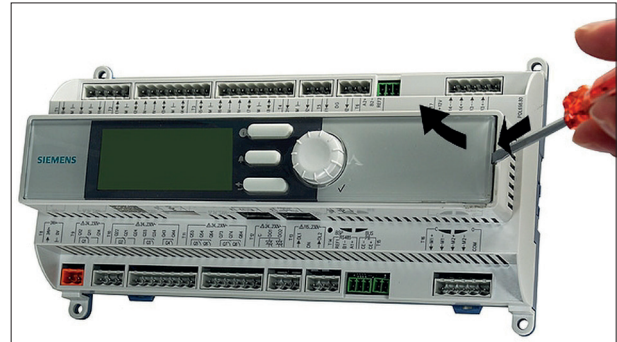

Lever out the plastic front cover on the right using a screwdriver with a small blade width.



Lift the plastic front cover and pull out to the left.

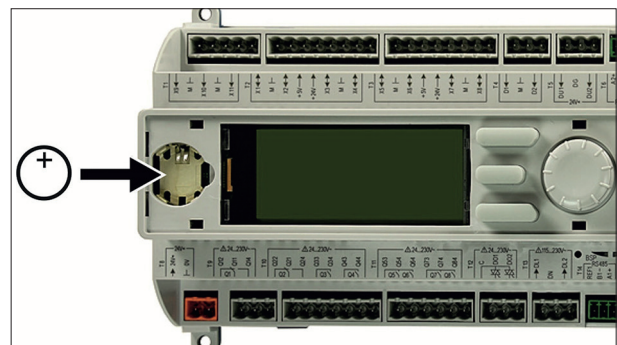

Replace button cell.

Note: Observe polarity! The plus sign is visible at the top and after insertion.

Refit the plastic front cover: First hook in the left side of the cover and then press on the right side until it snaps into place.

Spare parts, decommissioning

9. Spare parts, accessories

The following spare parts are available and may be ordered from LTG Aktiengesellschaft stating unit type and description:

| Quant. | Ident-No. | Description |
|--------|-----------|--------------------------------------------|
| 1 | 1089302 | Filter ePM1 80 % (corresponds to F8/F9) |
| 1 | 1089312 | Filter ePM10 50 % (corresponds to M5) |
| 1 | 1041369 | Heat recuperator |
| 1 | 1060475 | Fan |
| 1 | 1086376 | CO ₂ -/Temp. Sensor NOVOS 3 TLF |
| 1 | 1086577 | CO ₂ Sensor NOVOS 3 |
| 1 | 1047488 | Temperature sensor NI 1000 (0.9 m) |
| 1 | 1047487 | Temperature sensor NI 1000 (6 m) |
| 1 | 1019562 | Actuator for flap LF - 24- SR |
| 1 | 1041605 | Actuator Bypass CM 24 - SR - L |
| 1 | 1046550 | Controller |

The following **accessories** are available and may be ordered from LTG Aktiengesellschaft stating unit type and description.

| Quant. | Ident-No. z1 | Description |
|--------|-----------------|--------------------------|
| 1 | 1058390 | Remote switch FSG |
| 1 | 1047299 | HMI service tool |
| 1 | 1089874 | Room control unit WRF06S |
| 1 | 1051143 | BACnet module IP |
| 1 | 1056987 | BACnet module MS/TP |

10. Decommissioning, disposal

When the unit is taken out of service, is no longer used and is disposed of as waste, the following must be complied with:

- all steel parts are waste for recycling
- all plastic parts are waste for recycling
- all secondary materials and lubricants must be disposed of in accordance with local regulations and according to waste classes.



**AIR TECH
SYSTEMS**

Comfort Air Technology

Air-Water Systems
Air Diffusers
Air Distribution

Process Air Technology

Fans
Filtration Technology
HumidificationTechnology

Engineering Services

Laboratory Test & Experiment
Field Measurement & Optimisation
Simulation & Expertise
R&D & Start-up

LTG Aktiengesellschaft

Grenzstrasse 7
70435 Stuttgart
Germany
Tel.: +49 711 8201-0
Fax: +49 711 8201-720
E-Mail: info@LTG.net
www.LTG.net

LTG Incorporated

105 Corporate Drive, Suite E
Spartanburg, SC 29303
USA
Tel.: +1 864 599-6340
Fax: +1 864 599-6344
E-Mail: info@LTG-INC.net
www.LTG-INC.net